



# Design Span® hp Metal Roofing

## Installation, Flashings, & Details Guide





**Table of Contents**

<b>Section</b>	<b>Page</b>
Introduction .....	2-3
Delivery, Handling and Storage .....	4
Safety Considerations .....	4
Minimum Recommended Tools & Equipment .....	5
Roof Preparation .....	6
Existing Roofing .....	7
Map of Typical Roof Conditions .....	8
Fastener Selection .....	9
Panel Installation .....	10
Eave Flashing .....	11
Gutter Flashing .....	12
Hip/Ridge Flashing .....	13
Vented Ridge Flashing .....	14
Vented Ridge Termination .....	15
Gable Flashing .....	16
Gable Flashing Preparation at Ridge .....	17
Gable Flashing Preparation at Eave .....	18
Valley Flashing .....	19
Peak Flashing .....	20
Vented Peak Flashing .....	21
Sidewall Flashing .....	22
Endwall Flashing .....	23
Drip Flashing .....	24
Slope Transition - High to Low Slope .....	25
Slope Transition - Low to High Slope .....	26
Eave Transition .....	27
Vent Flashing .....	28
Skylight/Chimney Curb Details .....	29
Skylight/Chimney Flashing (Uphill) .....	30
Skylight/Chimney Flashing (Downhill) .....	31
Skylight/Chimney Flashing (Side) .....	32
Curb Preparation .....	33
Procedure for Joining Hems .....	34
Valley Top End .....	35
Valley Dormer .....	36
Appendix A - Drag Load Table .....	37
Appendix B - Fastener Schedule/ Drag Loads .....	38

## Design Span® hp

### Installation, Flashings, & Details Guide

## Introduction

In addition to weathertightness, long life and good looks, Design Span hp is designed with ease of installation as a primary consideration. This guide is intended to help the installer achieve a high level of quality in the finished product. Please do not hesitate to contact an ASC Building Products representative for assistance.

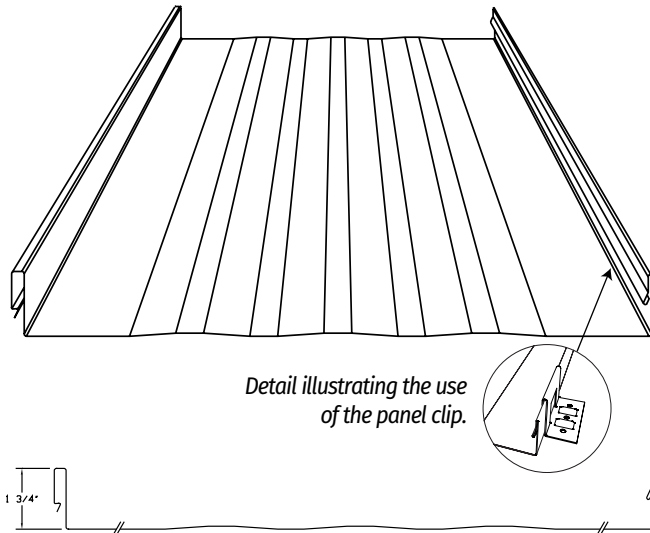

Detail illustrating the use of the panel clip.

### 12", 16" & 18" Coverage

(Design Span hp with 17" coverage is no longer standard, but is available for additions or replacements.)

### Design Span hp Panel Profile

#### Important Notice

**Be sure to read this manual in its entirety before beginning installation.**

This manual is provided to the customers of ASC Building Products as a guide to assist in the installation of Design Span hp. Use for any other purpose is prohibited. This manual remains the property of ASC Building Products.

These instructions contain suggested application procedures only and cannot replace the need for good common sense and experience. Responsibility for conformance to state and local building codes, as well as any other applicable project requirements rests with the installer, as does the responsibility to observe reasonable safety procedures.

Certain panel and flashing conditions such as panel overhangs, gutters, rake trim, etc, are easily damaged if a ladder is leaned against them. Care should be taken to avoid this.

Use only those accessories specifically designed for use with this product. Use only ZINCALUME®-coated flashings. Isolate roofing and flashings from contact with dissimilar metals.

ASC assumes no responsibility for any problems which might arise as a result of improper installation or any personal injury or property damage that may occur with the product's use.



IBC/IRC Building Code Compliance Report:  
Evaluation Report #ER-0309

#### Note:

- It is recommended that Design Span hp be applied on roofs with a minimum slope of 2 inches per foot (2:12).
- Each flashing part in this guide has been assigned a part number. Each part number contains one or two letters followed by one or two numbers, for example (EW41). These part numbers have been provided for you to make ordering these flashing parts quick and easy.
- To prevent mis-alignment of fasteners and "walking" drill bits, it may be advisable to pre-drill certain flashings before they are installed.

#### Notes to the Designer/User

The details contained in this installation guide are intended to be a design aid and do not depict all situations. Modifications are the responsibility of the designer/user and should take into account climate conditions such as wind and snow, governing code requirements, and the actual usage and maintenance of the structure. Where possible, roof panel side laps and flashings should be lapped away from prevailing winds. Certain flashings should be supported if it is likely that a ladder will be used against them or if foot traffic is anticipated. Check with ASC Building Products any time you intend to specify a prefinished flashing in a gauge different than the panels. Our standard gauge for all of the products in this guide is 24 gauge and the standard finish is Dura Tech 5000 (non-metallic colors) and Dura Tech mx (metallic colors). These premium Polyvinylidene Fluoride (PVDF) finishes are applied by coil coaters experienced in handling 70% Kynar 500® and Hylar 5000® resin-based coatings. Product is also available bare in a ZINCALUME finish. ZINCALUME is comprised of 45% zinc and 55% aluminum and meets ASTM A792. It is good practice to specify that all flashings be of the same material (gauge, color, finish) as the roof panels to ensure long-term durability. Field-painted flashings rarely equal the durability and colorfastness of factory baked-on paint systems. Where possible we have minimized the use of exposed fasteners and have hemmed the edges of flashings to strengthen them and to minimize the exposure of cut edges.

#### Substrates

These details show the roofing panels over solid substrates. Design Span hp roofing panels can also be used over spaced support members.

#### Slope Requirements

The panels in this booklet should be used on slopes of 2:12 or greater.

### Condensation, Insulation, & Ventilation

It is the designer’s responsibility to determine the need and composition of condensation control materials including insulation and vapor retarders, as well as ventilation requirements. Metal roofing is susceptible to condensation and its control should be carefully considered. Applications over rigid insulation may require solid blocking/framing for installation of perimeter flashings and to resist drag loads.

### Underlayments

Prior to panel installation a minimum of 30 lb. felt (or two layers of 15 lb. felt) should be installed per the felt manufacturer’s recommendations. The underlayment should be lapped with all flashings in a shingle-like manner. When a premium underlayment is required, a self-adhering, rubberized membrane underlayment should be utilized. ASC Building Products’ **AEP Span Underlayment HT** is an approved premium underlayment. A high temperature rated premium underlayment is preferred. The use of “plastic capped” underlayment fasteners is not recommended for any underlayment. NOTE: Class A fire rated roof assemblies have additional underlayment restrictions. Refer to Page 6 for further details.

### “Pinning” Requirements

The panels must be “pinned” at the top to resist the “drag” load caused by the weight of the panel, live loads, and snow loads. The intensity of the drag load is a function of slope, the loads involved, and the length of the panels. Appendix “A” give the drag loads for various slopes and loading conditions, and Appendix “B” shows the fasteners required to resist the drag load. Contact an ASC Building Products’ representative for more information.

### Expansion & Contraction

Both the panels and the flashings must allow for expansion and contraction of the materials, especially where long lengths are used. The overlap between the hidden cleat and the turned-under end of the panel at the eave may need to be increased to accommodate thermal movement of the panels.

### Valleys

Valley dimensions must be the proper width to account for slope, snow, ice, and rain conditions. Valleys should receive a special underlayment since they are susceptible to water buildup. If valleys are not kept free of debris and water does back up, intrusion may occur under the panels. An underlayment such as a self-adhering cold-applied rubberized asphalt membrane should be put down first, extending 3 ft. up from the center of the valley on each side. The 30 lb. felt should then overlap this underlayment.

### Snow Design

An integral seam panel, such as Design Span *hp*, is suited for light snow loads. If possible, valleys, gutters, roof elevation changes and penetrations should be minimized or eliminated in snow areas. Roof penetrations should be located as close to the ridge or peak of the roof as possible to minimize accumulations of ice and snow and the effects of thermal movement of the roof panels. Special membrane underlayments should be used. Valleys in snow areas require special consideration due to the accumulation of snow and ice from tributary roof areas.

### Oil-Canning

Flat metal surfaces will display waviness commonly referred to as ‘oil-canning’. This is caused by steel mill tolerances, variations in the substrate and roofing underlayments. Oil-canning is a characteristic, not a defect, of panels manufactured from light-gauge metal. Oil-canning is not a cause for panel rejection. Additional information, including a Technical Bulletin on oil canning is available upon request.

### References

The Sheet Metal and Air Conditioning Contractors’ National Association Inc. (SMACNA) manual is an excellent reference for sheet metal contractors. Its guidelines for underlayments, gutter and downspout size requirements, and expansion/contraction of metals and flashing joints should be followed. Additional sources for information include the National Roofing Contractors Association ([www.nrca.net](http://www.nrca.net)) and the Metal Construction Association ([www.metalconstruction.org](http://www.metalconstruction.org)).

### Technical Assistance

Call your ASC Building Products Sales Representative for additional information on any of these subjects.

### Definitions

**Sealant:** Gunnable-grade single-component polyurethane

**Mastic:** Butyl mastic tape or butyl rubber

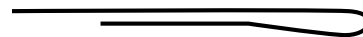

**Hem:** A 180° bend that is closed (or as closed as the formability of the metal will allow) to provide a uniform, attractive edge. High tensile strength (Grade 80) steel must be formed with a “teardrop hem” as shown to avoid cracking the steel at the bend. Lower tensile steels can be flattened close.



**Hook:** (also called an “open hem”) A 180° bend on a piece of sheet metal that is left open to allow insertion of another piece of sheet metal. For example, the hook shown is used to hold the trim piece to a cleat below the trim.

## Delivery, Handling and Storage

- Always check the shipment upon delivery. Check for damage and material quantities against the shipping list. Note any damaged material or shortages at the time of delivery.
- Handle panel bundles and individual panels with care to avoid damage. Longer bundles and panels may require two or more “pick points,” spaced no farther than 10’ apart, to avoid damage that can result from buckling and/or bending of the panels. Request a copy of the Long Length Handling Instructions and diagrams from the ASC customer service as required.
- Improper storage of product can result in damage to the finish known as Wet Stack Staining. Store the panels and other materials in a dry, well ventilated area and away from traffic. Elevate one end of the bundle to prevent moisture from settling on the panels. Be sure that air will be able to circulate freely around the bundles to avoid the build-up of moisture. Cover the product with a tarp and allow for air circulation around and under the tarp and bundle of material. Minimize field storage of material. Contact with wet cement should be avoided. Damage due to improper storage is not the responsibility of ASC.
- Painted panels are shipped with a protective plastic sheeting or a strippable film coating between all panels. Remove any strippable film coating prior to installation and in any case, do not allow the strippable film coating to remain on the panels in extreme heat, cold, or in direct sunlight or other UV source.
- Wear clean cut resistant gloves when handling unpainted ZINCALUME®-coated panels or flashings to avoid discoloration. Rollforming die marks (which appear black), particularly at bends, will be visible. Care should be taken when handling steel material including panels and trim. Additional protective clothing and attire may be required.
- Wear clean, non-marking, soft soled shoes when walking on the panels to avoid shoe marks or damage to the finish. Do not step on the panel seams or ribs. Step only in the flat area of the panel. Repeated foot traffic on the roof can damage the panel finish.
- **Never use unsecured or partially installed panels as a working platform.**  
Do not walk on panels until they are in place on the roof and all of the fasteners attaching the panels to the roof have been installed.

## Safety Considerations

- **Metal roofing panels are slippery when wet, dusty, frosty or oily.**  
Do not walk on a metal roof when any of these conditions are present. Wearing soft soled shoes will help minimize slipping and help prevent damage to the painted surfaces.
- **Do not walk on the panel seams.**  
When walking on the fully installed roof panels, be sure to step only in the flat areas of the panels.
- **Always be aware of your position on the roof relative to your surroundings.**  
Take note of the locations of roof openings, roof edges, equipment, co-workers, etc.
- **Always wear proper clothing and safety attire.**  
Wear proper clothing when working with sheet metal in order to minimize the potential for cuts, abrasions, and other injuries. At a minimum, ASC Building Products suggests wearing safety glasses, cut resistant gloves and arm guards.
- **Use care when operating electrical and other power equipment.**  
Observe all manufacturer’s safety recommendations.
- **Roof installation on windy days can be dangerous.**  
Avoid working with sheet metal products on windy days.

## Minimum Recommended Tools & Equipment

### Screws/Screw bits:

A clutch type screw gun with depth locating nose piece allowing variable torque settings is recommended to insure proper installation of the fasteners. The following bits will be required: 5/16" hex and No. 2 Phillips screwdriver bit.

### Snips:

For miscellaneous panel and flashing cutting requirements. Three pairs of snips will be required for left edge, right edge, and centerline cuts.

### Electrical Metal Shears:

Used for general metal cutting, such as at the hips and valleys

#### Note:

*Some erectors prefer to use circular power saws with metal cutting abrasive blades. While the use of power saws may be faster, there are some disadvantages that must be considered:*

- (1) The edges of metal that have been saw cut are jagged and unsightly, and are more likely to rust than sheared edges.*
- (2) Saw cutting will leave small particles of metal on the panel surface that will rust and damage the panel finish if not completely removed. If using abrasive blades to cut panels make sure that none of the metal particles land on painted steel panels or flashings since they can burn the paint.*

### Chalk Line:

Used to assist in the alignment of panels, flashings, etc.

### Caulking Gun:

For miscellaneous caulking and sealing to inhibit water infiltration.

### Rivet Tool:

Used for miscellaneous flashing and trim applications.

**Turn-Up/Turn-Down Tool:** Available from ASC, a turn-up/turn-down tool is used to hand brake the ends of the panels as indicated in the details of this manual.

### Marking Tools:

Indelible markers, pencils, or scratching tools.

### Scratch Awl:

Used to mark the steel.

### Utility Knife:

Used for miscellaneous cutting.

### Electric Drill:

Used to drill holes such as those required for rivet installation.

### String Line:

Used for general alignment and measuring.

### Tape Measure:

25 ft. minimum (another 50 ft. handy)

### Locking Pliers:

Standard in "Duckbill" style for miscellaneous clamping and bending of parts.

### Hammer:

Used with roofing nails to fasten flashings.

#### Important Note:

*At completion of each day's work and at completion of roof installation, sweep panels, flashings, and gutters clean. Take special care not to sweep metal shavings down into the gutters. Do not allow fasteners, cuttings, filings, or scraps to accumulate; this will damage the panel finish over time.*

## Design Span® hp

Installation, Flashings, & Details Guide

### Roof Preparation

Design Span hp can be used in both new construction and retrofit roofing applications. We recommend the installation of Design Span hp over a continuous rigid substrate such as plywood/OSB, or closely spaced sheathing. All substrates must be complete, accurately sized and located, in true plane, secure and otherwise properly prepared. Contact ASC for additional information.

The following steps need to be taken to prepare the roof for installation of Design Span hp panels:

#### New Roofs:

1. Make sure there are no nails or other objects protruding from the substrate that might puncture the underlayment or the roof panels. Clean all debris from the roof.
2. Check all details for possible roof penetrations which must be added to the deck prior to roof panel installation.
3. Cover the entire roof deck with minimum 30 lb. asphalt saturated felt paper. Some synthetic underlayments may be used in place of felt with ASC Building Products' Design Span hp. Installer must ensure they meet the minimum standards of 30 lb felt and that the underlayment manufacturer has approved them for use with metal roofing. (Check with an ASC Building Products representative if project is in snow country). **For Class A fire resistance, see notes below.** For installation begin at the eave and roll the felt horizontally (parallel to the eave). Allow each consecutive course to overlap the previous one 3". Overlap the ends a minimum of 6" when starting a new roll of felt. (See illustration #1). Areas of underlayment that have torn should be replaced or repaired prior to installation of the metal roof.

#### CONSTRUCTIONS REQUIRING CLASS 'A' FIRE RESISTANCE:

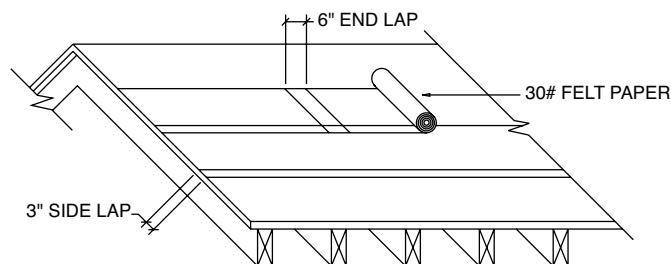

**Illustration No. 1**

**Panel:** ASC Building Products' Design Span hp steel roof panels.

#### Barrier Sheet (one of the following):

- GAF VersaShield® Underlayment
- Firestone GLAD-GARD™ SA-FR
- Polyglass Polystick® XFR
- Georgia-Pacific DensDeck® Roofboard

**Additional Ply Sheet (optional):** Any UL Classified Type G1, G2 or G3 base/ply sheet, Type 15, 20 or 30 felt or UL Classified Prepared Roofing Accessory (TGDY) or ASC Building Products' "AEP Span Underlayment HT".

**Substrate:** 15/32" min. plywood or 7/16" min. OSB

#### Notes:

- Obey all local code requirements. Some jurisdiction have special requirements for roofs in high fire risk areas.
- Class A assembly requirements noted above per UL listing #TGFU.R16747. Refer to UL listing for specific construction limitations.

4. Place an alignment line along the gable end where the first roof panel will be installed. This line must be located 1/4" in from the gable edge of the roof deck and square with the eave line. Various methods exist for insuring that the line is square. Contact your ASC representative if you need assistance (See illustration #2).

#### Notes:

Check with the underlayment supplier for specific installation and handling instructions. Over exposure to the elements may cause buckling of the felt resulting in an objectionable appearance of the installed roof.

Design Span hp and trim materials should not come in contact with or run-off from CCA, ACQ, CA, or other treated lumber or fire retardant impregnated or treated wood shakes or siding. Contact with these materials can cause panels and trim to fail prematurely.

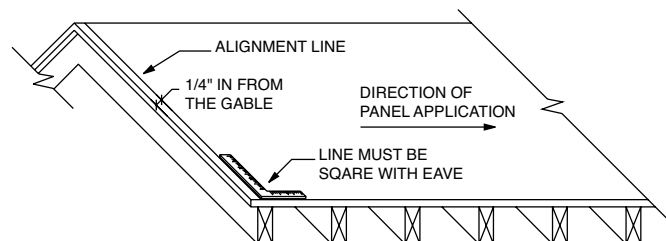

**Illustration No. 2**

## Existing Roofing:

Some jurisdictions will allow reroofing over existing roofing without the need for tearoff. Check with your local codes or building department for your specific requirements.

For best results, Design Span *hp* requires a relatively smooth and flat substrate. Application over rough and/or uneven surfaces is not recommended.

If the roof is to be stripped down to the existing decking, follow the procedures for new roofs. Be sure to check the existing roof and repair any damaged areas prior to installation of the new roof system.

**Notes:**

*Do not apply Design Span *hp* over roofs with structural damage or trapped moisture.*

*Design Span *hp* and trim materials should not come in contact with or run-off from CCA, ACQ, CA, or other treated lumber or fire retardant impregnated or treated wood shakes or siding. Contact with these materials can cause panels and trim to fail prematurely.*

### The following steps should be taken when installing ASC's Design Span *hp* over existing roofing:

1. Inspect the roof for damage and make the necessary repairs to achieve a flat plane for the metal roof panels.
2. Secure any warped or loose roofing.
3. Make sure that there are no nails or other objects protruding from the roof that might puncture the new underlayment or the new roof panels.
4. Remove all moss and other debris from the roof.
5. Cut off any overhanging roofing flush with the roof deck and remove all hips, ridge caps, and penetration flashings.
6. Follow the directions for roof preparation.





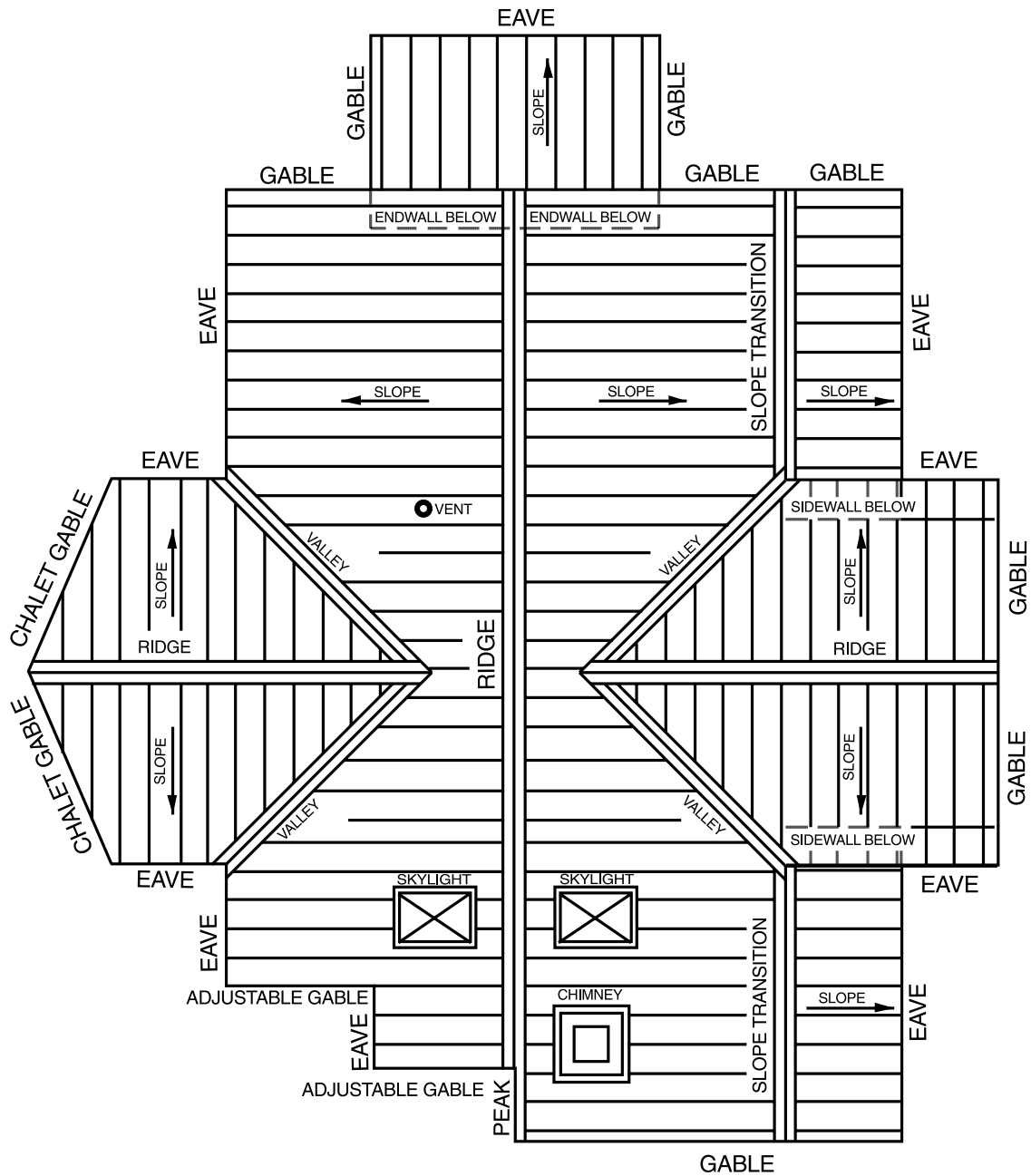





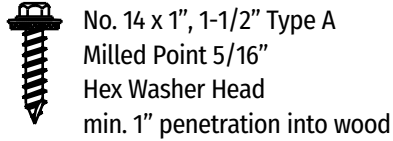

## Map of Typical Roof Conditions

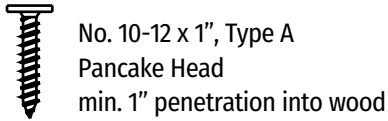

For suggestions on how to trim flashings in the different areas, please refer to the following pages:

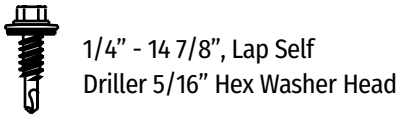
<b>Flashing</b>	<b>Page(s)</b>	<b>Flashing</b>	<b>Page(s)</b>
Chimney .....	29-33	Slope Transition .....	25-26
Dormer.....	36	Ridge & Hip.....	13
Eave.....	11	Sidewall.....	22
Endwall .....	23	Skylight .....	29-33
Gable .....	16-18	Valley .....	19, 35-36
Gutter.....	12	Vent.....	28
Peak .....	20		

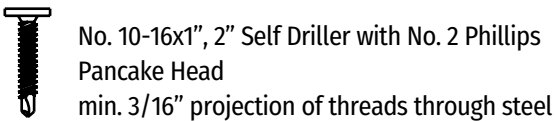
## Fastener Selection

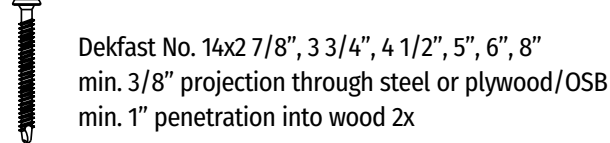
Fastener #	Description	Use
		Panel to wood substrate for fixed points.
		Trim to trim attachments.
		Clip or flashing attachment to wood.
		Trim to panel attachments or for fixing panel to steel (16 ga. or thinner).
		For clip or flashing attachment to steel substrate.
		For clip or flashing attachment over rigid insulation.

### Notes:

- The table above shows the fasteners required for Design Span hp. Refer to the panel installation and flashing details of this manual for specific screw usage and spacing.
- Panel attachment screws must be long enough to fully penetrate through the wood roof decking, or penetrate solid lumber at least one inch.
- All fasteners shall be zinc-plated with an added corrosion resistant coating, or of a 300 series stainless steel construction. This is to avoid galvanic corrosion from dissimilar metal contact. **For this reason lead, copper and copper containing alloys should not be used in conjunction with ZINCALUME Steel.** Stainless steel should not be used in severe salt environments as the ZINCALUME coated panels and trim can corrode sacrificially. Contact ASC representative for information on fastener selection.
- Exposed fasteners must have sealing washers and should be the same color as the parts they attach.
- Roofing nails are also required, but are not furnished by ASC Building Products. **Do not use lead headed nails.** ZINCALUME Steel, in contact with, or receiving run-off water from, lead is prone to corrosion.
- Screws must be properly driven to ensure proper seal and holding strength. Do not under-drive or overdrive the screws.
- All the flashing details show plywood/OSB as the substrate to be attached to with a symbol  showing which fastener to use. If other substrates are used, different fasteners must be used to attach to the substrate.

### Proper Installation of Gasketed Fasteners

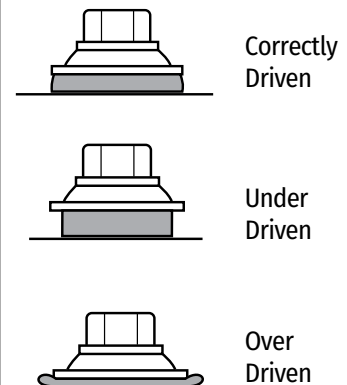

## Panel Installation

### General

Study the details section of this manual prior to the installation of the panels. Pay close attention to the following:

- Design Span *hp* must be installed from left to right.
- Some panels may require “turn-up” at the uphill end prior to their installation.
- Apply sealant to the pre-installed flashings per the instructions in the detail section of this manual.

### Procedure

1. Turn under the downhill side of the panel, creating a hook for installation.
2. Align the female edge of the first panel with the alignment line constructed along the start gable.
3. Check the downhill end of the panel. Make sure the female edge of the panel remains 1/4” from the gable and leave 1/8” of space per 10’ of panel length between the eave flashing and hook per 10’ of panel (allows for expansion/contraction).
4. After the first panel is properly aligned, fasten the panel at the ridge. Then, refer to drag load table on pages 37 and 38 for recommended number of fasteners.
5. Fasten panel clips at the recommended spacing per detail.
6. Align the second panel female edge with the first panel male edge. Make sure the panels are flush with each other.
7. Snap the panels together at the seam with light foot pressure. Work the seam together from the eave end toward the ridge. DO NOT work the seam from both ends toward the middle.
8. Apply subsequent panels as in items #4 through #7 above.

**Table 1: Panel Attachment & Outward (Wind Uplift) Load Capacities<sup>1,2</sup>**

Panel Width	Panel Gage	Plywood / OSB Thickness Min.	Fastener Size	Fastener Spacing	Basic Wind Speed Met (mph) <sup>3</sup> (IRC only)	Outward Wind Load Capacity (psf) <sup>4</sup> (IRC and IBC)
16"	22, 24	15/32"	#10 min	2'-0"	110	30
		19/32"			120	36
18"	22, 24	15/32"	#10 min	2'-0"	X	26
		19/32"			120	34

**Notes:**

1. Only select panel configurations are noted in the table above and have been simplified for user ease. Refer to IAPMO-UES Building Code Compliance Report #ER-0309 for a more complete list of panel attachments and performance data. More efficient panel attachment patterns may be available.
2. The table above addresses outward wind loads. Inward gravity loads (snow, etc.) are also resisted by the substrate. Substrate thickness should also be evaluated to appropriately account for these inward loads.
3. Basic Wind Speed Met is based on 2018 International Residential Code (IRC) code provisions (IRC Section R301.2.1) using the following assumptions: Slope >2:12, Wind exposure =B, Mean roof height ≤ 30', No topographic effects. These values only apply to projects that fall under the 2018 IRC. For applications beyond the assumptions above, please refer to IRC Section R301.2.1 for necessary adjustments, or consult a design professional for assistance.
4. Outward Wind Load Capacities are taken from IAPMO-UES Building Code Compliance Report #ER-0309. For projects governed by the International Building Code (IBC), consult the Engineer of Record to determine if stated capacities meet or exceed the project's outward wind load requirements. The capacities stated in the table can also be used for IRC governed projects.

## Eave Flashing

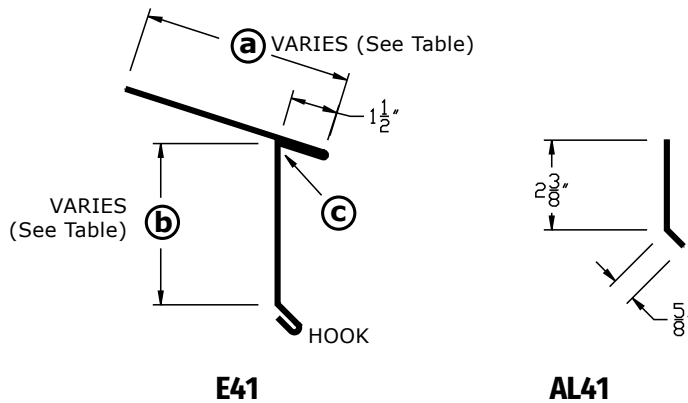

Roof Pitch	(a)	(b)	(c)
2:12*	5"	4 1/4"	81°
3:12	5"	4 1/4"	76°
4:12	5"	4 1/4"	72°
5:12	5"	4 1/4"	67°
6:12	4 5/8"	4 5/8"	63°
7:12	4 5/8"	4 5/8"	60°
8:12	4 5/8"	4 5/8"	56°
9:12	4 1/8"	5 1/8"	53°
10:12	4 1/8"	5 1/8"	50°
11:12	3 5/8"	5 5/8"	47°
12:12	3 5/8"	5 5/8"	45°

\*Inquire for slopes below 2:12

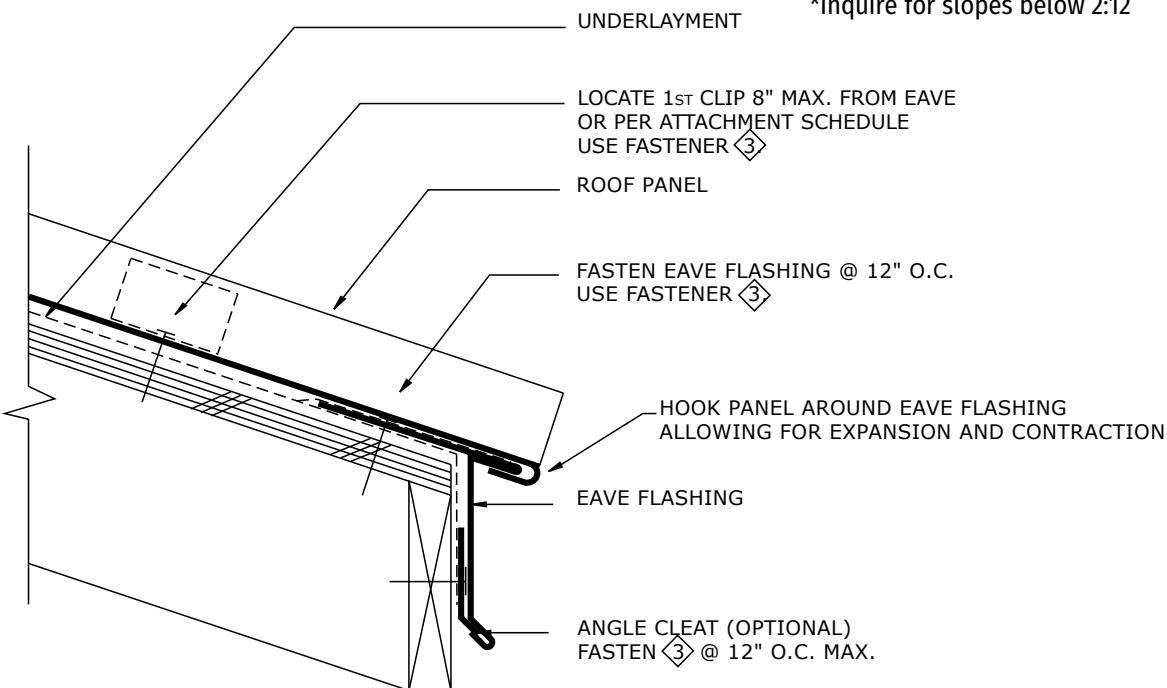

### Procedures

- Locate angle cleat and fasten before installing the eave flashing. If the angle cleat is not used, fasten through the vertical leg of the eave flashing with #14 wood screw every 24" o.c. max.
- Hook the panel around the eave flashing. Leave a gap to allow for expansion and contraction of the panel. Rule of thumb is 1/8" movement for every 10 ft. of panel length.
- Caulk and lap the eave flashing a minimum of 3" (See procedure for joining hems).
- Heavy weather conditions may require a rubberized cold applied membrane underlayment to be applied over the eave flashing.

**Note:** Consult with ASC for spacing in between eave flashing and hook for panels that exceed 40 ft.

## Gutter Flashing

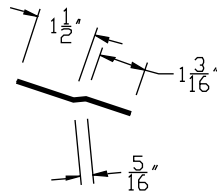

### OL41

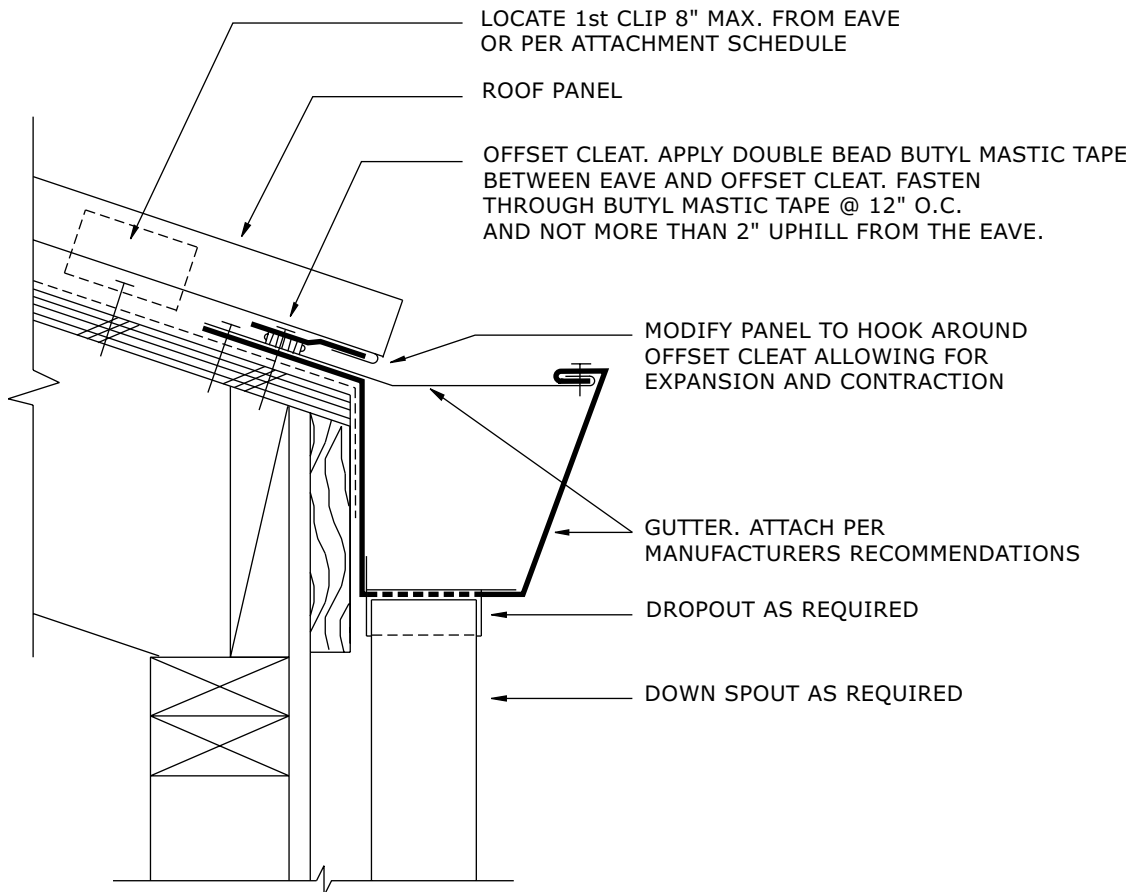

### Procedures

- All carpentry should be completed prior to installation of gutter flashing and offset cleat.
- It is recommended that a licensed gutter contractor install the gutter.

## Hip/Ridge Flashing

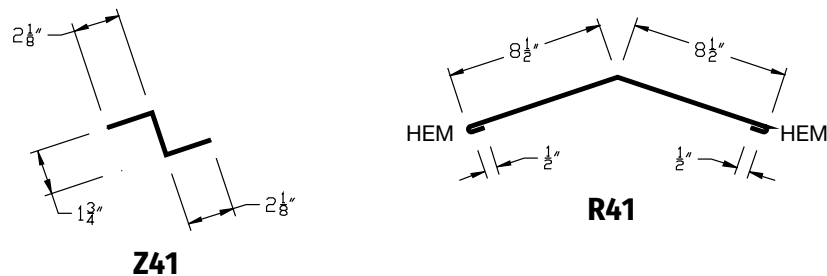

3 FASTENERS  PER PANEL  
MIN. SEE DRAG LOAD TABLES  
PGS. 36 & 37.

Z-CLOSURE. CUT TO FIT  
BETWEEN BATTENS/PANEL  
LEGS.

HIP/RIDGE

ROOF PANEL

TURN UP PANEL IF NOTCHED

DOUBLE BEAD BUTYL MASTIC TAPE.  
CAULK ENDS OF Z AGAINST PANEL LEGS.

FASTENER  HIP/RIDGE TO  
Z-CLOSURE @ 12" O.C. MAX.

CLIP SHOULD BE A MAX. OF 24"  
FROM END OF PANEL. FOR CLIP  
SPACING REFER TO ATTACHMENT SCHEDULE.  
USE FASTENER 

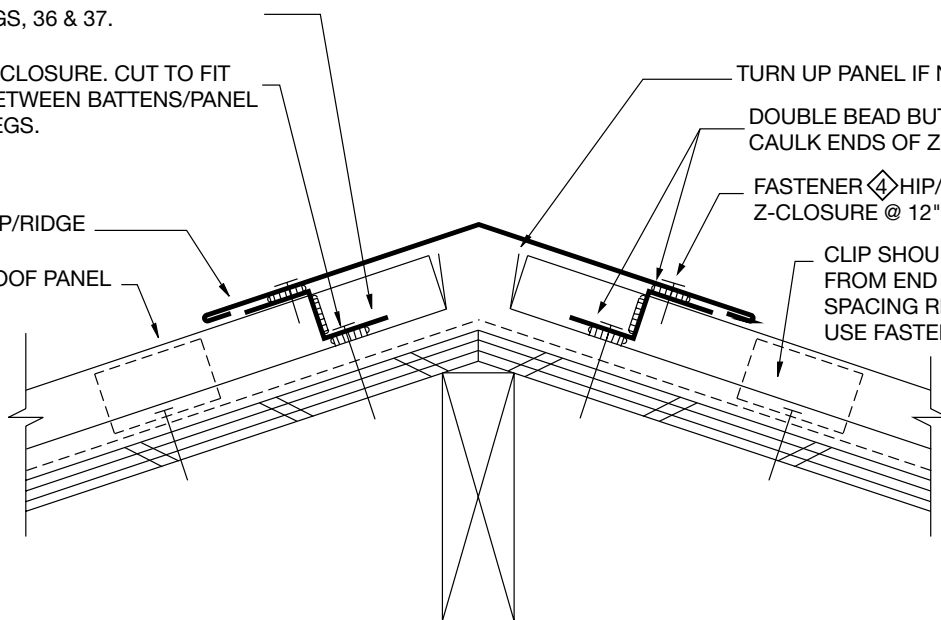

### Procedures

- Locate the panels down from the ridge as required. Check the panel position at the eave. (See pg. 11).
- Turn up end of panels if notched. If panels are factory notched, 1-1/8" notches are provided on BOTH ends of panel. Ordered panel lengths must be adjusted accordingly to account for the combined 2-1/4" of notched length.
- Locate the panels down from the ridge as required and position Z closures so that the hip/ridge cap will conceal them.
- Apply double bead butyl mastic tape to top and bottom of Z closure.
- Caulk sides of the Z Closure. Check the overlap at the eave before fastening the Z Closures to the substrate.
- Fasten Z Closure to substrate and fasten hip/ridge flashing to the Z Closures.
- Caulk, lap, and rivet sequential flashings. Recommended that maximum accumulated length does not exceed 40 ft.

## Vented Ridge Flashing

Note: The gable flashing must be installed prior to installation of the ridge. (See page 16)

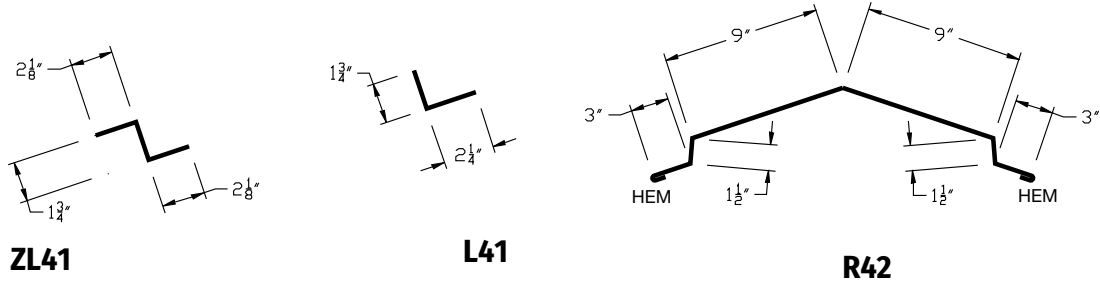

Z-CLIP (PRE-PAINTED TO MATCH ROOF PANELS) WITH 1 FASTENER PER CLIP. APPLY SEALANT OR MASTIC BETWEEN PANEL AND CLIP.

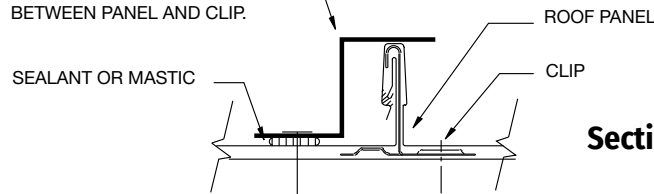

**Section A-A**

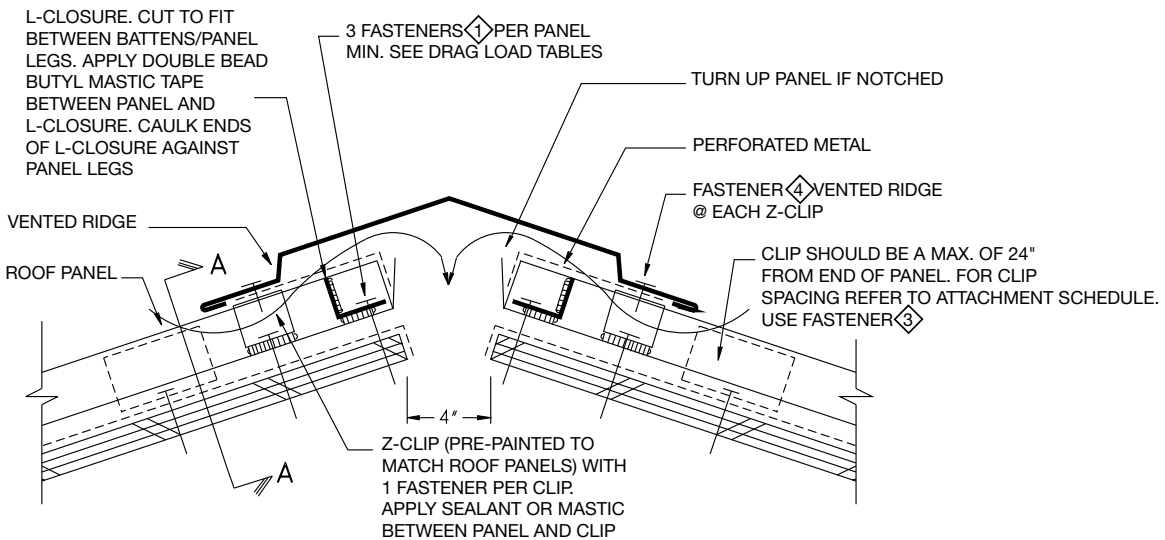

### Procedures

- Turn up end of panels if notched. If panels are factory notched, 1-1/8" notches are provided on BOTH ends of panel. Ordered panel lengths must be adjusted accordingly to account for the combined 2-1/4" of notched length.
- Locate the panels down from the top edge of the substrate as required.
- Apply double bead butyl mastic tape to bottom of L-Closure. Caulk ends of L-Closure against panel ribs. Locate the L-Closure so that air may pass through the perforated closure. Check the overlap at the eave before fastening the L-Closure to the substrate.
- Locate the Z Clip so that the Vented Ridge can be fastened to it.
- Caulk the bottom of the Z Clips and fasten.
- Set the perforated metal on top of the roof panel and Z Clips. Fasten the Vented Ridge flashing, perforated metal and Z clips as shown.
- Caulk, lap, and rivet sequential flashings. We recommend that maximum accumulated length of flashings do not exceed 40 ft.
- Close the end of the Vented Ridge Cap by slitting and folding the material at each end, caulking joints, and fastening with rivets (See vented ridge termination).

# Vented Ridge Termination

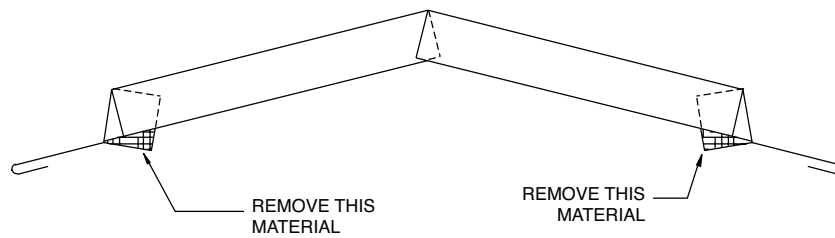
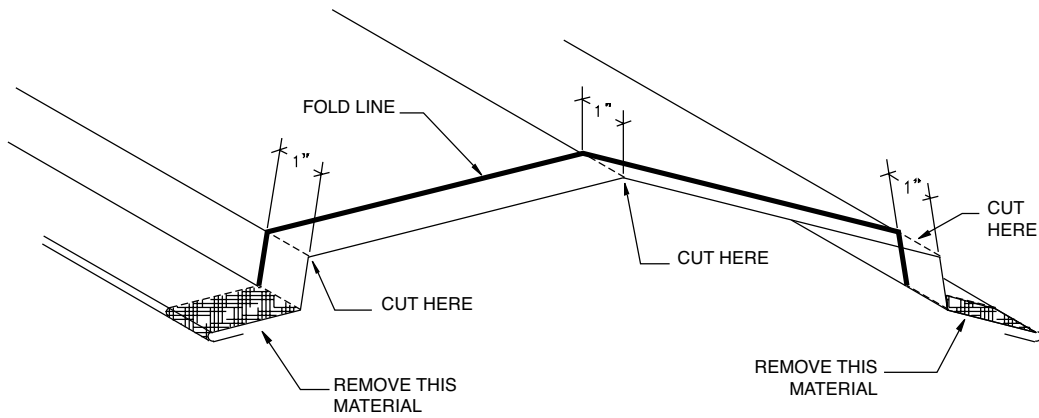
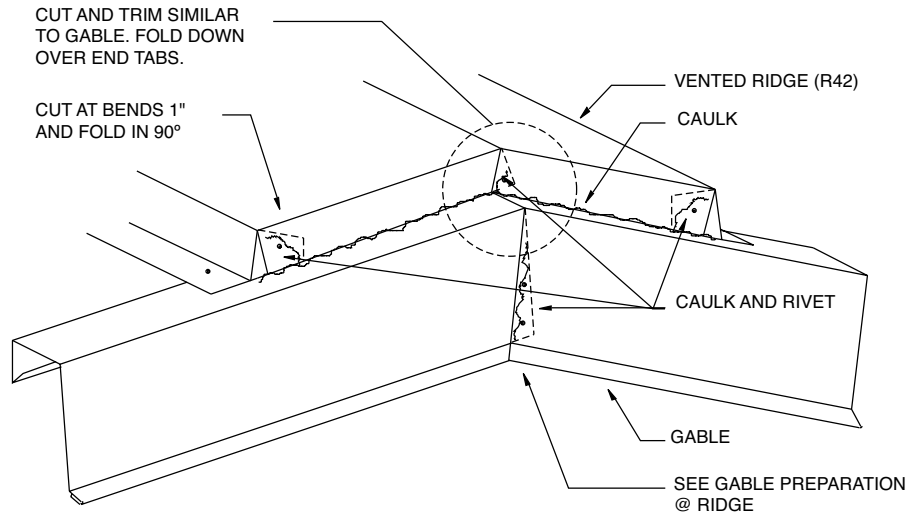



## Gable Flashing

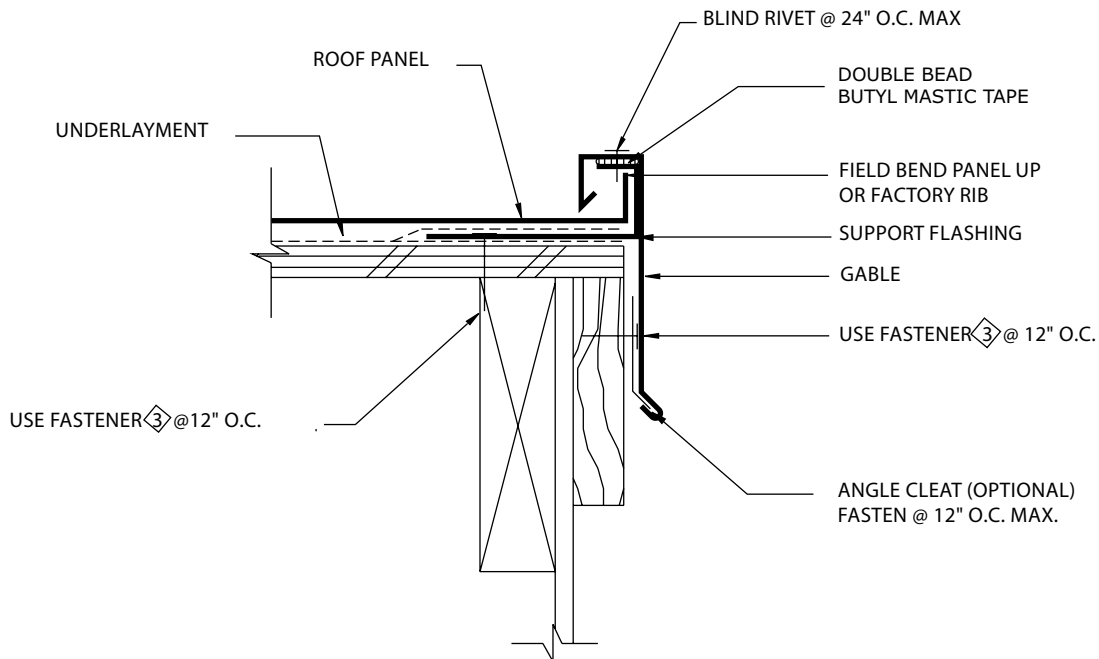
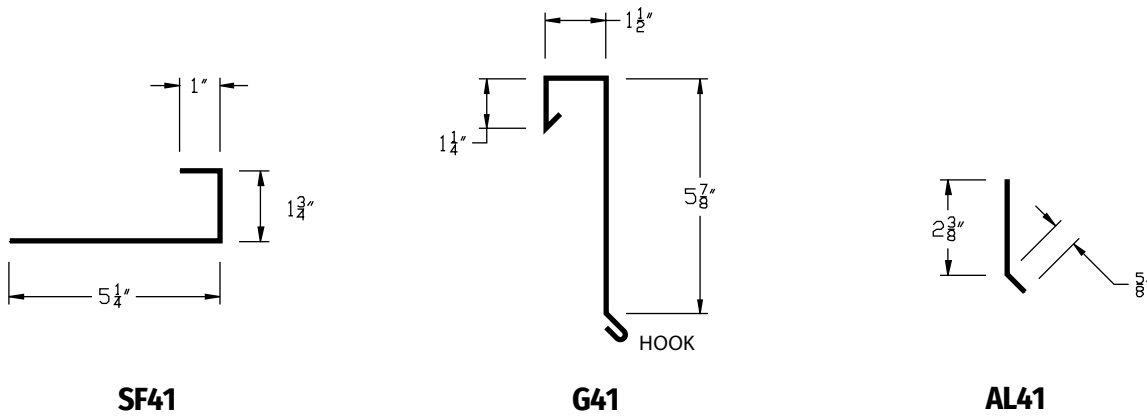

### Procedures

- Install support flashing before installing roof panel.
- Place the first roof panel along the alignment line (line that is square to the eave). Always install panels left to right.
- Locate angle cleat and fasten before installing gable flashing. If angle cleat is not used, rivet the gable to the sealed support flashing and then fasten through the vertical leg of the gable with a #14 wood screw every 24" o.c. max.
- Caulk, lap, and rivet sequential flashings. We recommend that maximum accumulated length of flashings do not exceed 40 ft.
- Snip, caulk, fold, and rivet the gable flashing at the ridge and eave (See gable preparation at ridge and eave)
- Heavy weather conditions may require a rubberized cold applied membrane underlayment to be applied over the gable flashing.

## Gable Flashing Preparation at Ridge

### Step One

Remove a pie-shaped piece from the gable flashing as shown below.

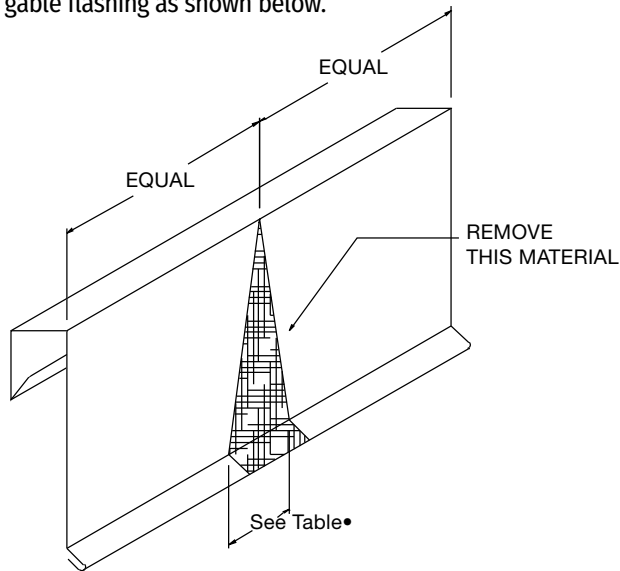

Roof Pitch	Dimension
2:12*	7/8"
3:12	1 7/8"
4:12	2 7/8"
5:12	3 3/4"
6:12	4 3/4"
7:12	5 3/4"
12:12	0"

\*Inquire for slopes below 2:12

### Step Two

Notch out the downturn leg on the gable as shown below.

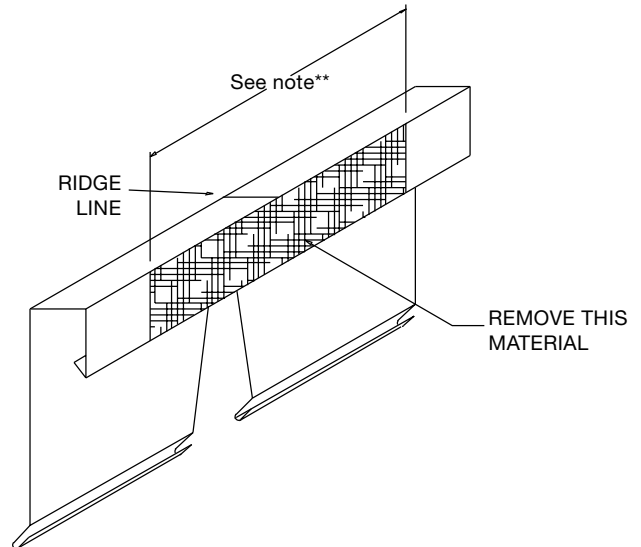

**Note:** Make opening large enough to fit over Zee Closures for a standard ridge and large enough to fit over the perforated metal pieces for a vented ridge.

### Step Three

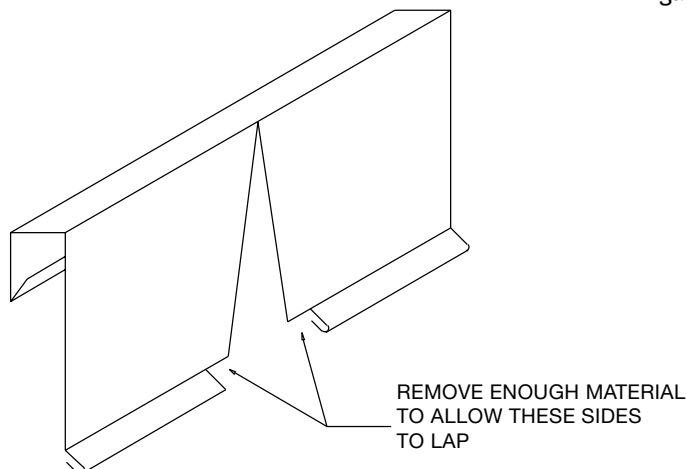

### Step Four

Center the flashing on the ridge at the gable and bend to roof pitch

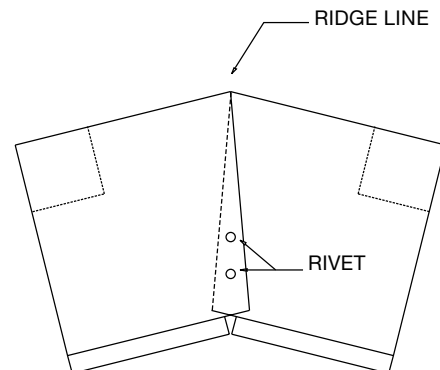

## Gable Flashing Preparation at Eave

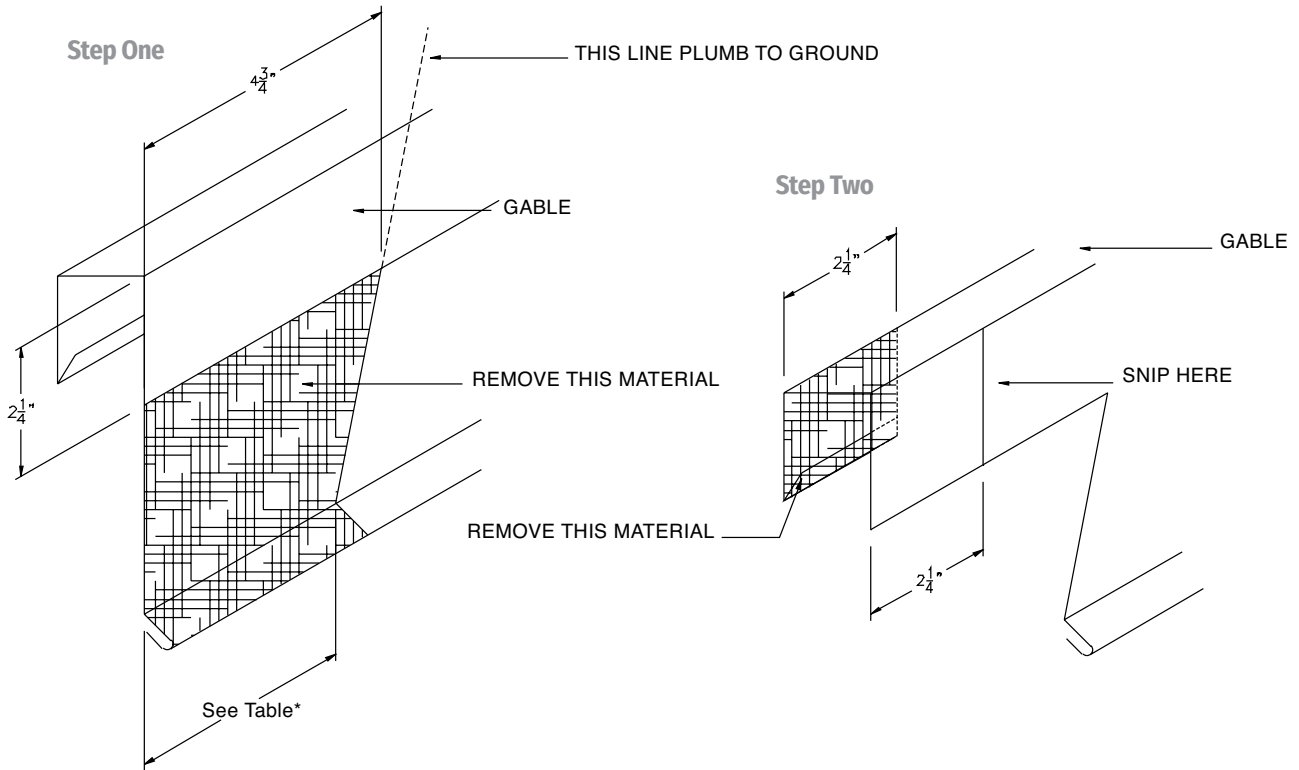

### Step Three

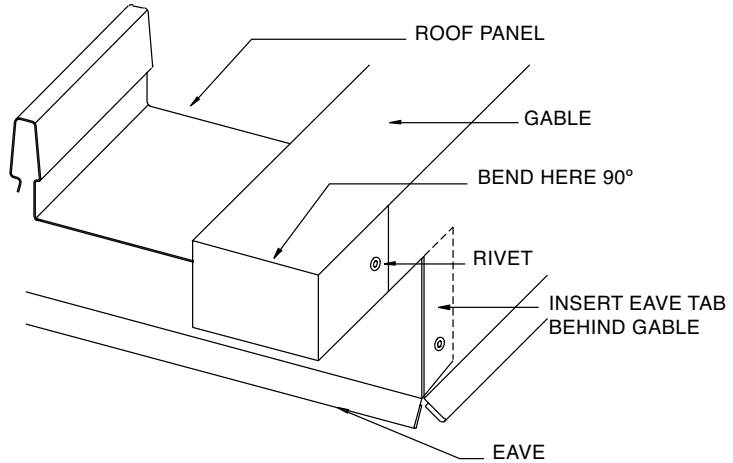

Roof Pitch	Dimension
2:12*	4"
3:12	3 3/4"
4:12	3 7/16"
5:12	3 1/16"
6:12	2 3/4"
7:12	2 1/2"
12:12	0"

\*Inquire for slopes below 2:12

## Valley Flashing

Note: This flashing must be installed prior to the panels.

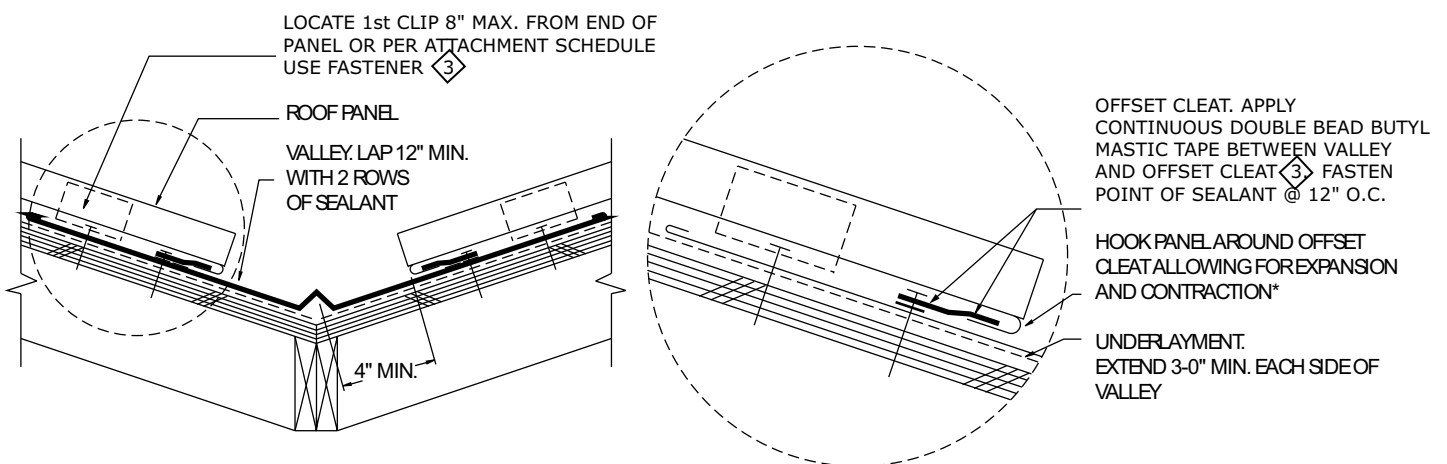
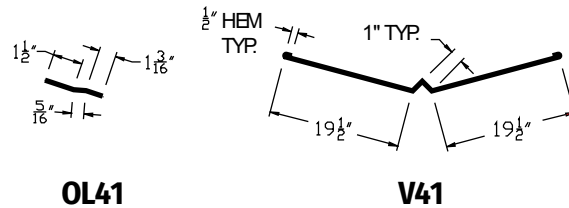

Note:

- Minimum slope for this detail is 2:12.

### Procedures

- Place a second layer of 36" roof felt in the valley centerline with 18" on each side.
- Place the valley over the membrane and make sure the downhill end of the valley overhangs the edge of the roof by 1".
- Locate the offset cleats and butyl mastic tape as shown. Make sure the end of the roof panels are at least 4" back from the center of the valley flashing. Leave a gap to allow for expansion and contraction of the panel. Rule of thumb is 1/8" movement for every 10 ft. of panel length.
- Fasten the offset cleat through the upper row of sealant.
- Caulk and lap the subsequent valley flashings a minimum of 8". We recommend that maximum accumulated length of flashings do not exceed 40 ft.
- Cut, caulk, fold, and secure the downhill end of the valley as needed. Also make sure to fill in the triangular opening with caulk.

- Valley dimensions must be the proper width to account for slope, snow, ice, and rain conditions. An underlayment such as a rubberized cold-applied membrane is recommended. The membrane is installed first, extending 3'-0" up from the center of the valley on each side, with felt overlapping the membrane.

**Note:** Refer to applicable building codes to ensure roof valley construction meets code requirements. Certain jurisdictions, like wildfire prone areas, may require different construction methods or materials.

- \* Consult with ASC for spacing in between cleat and hook for panels that exceed 40 ft.
- \* Consult with ASC if heavy snow and ice conditions exist.

## Peak Flashing

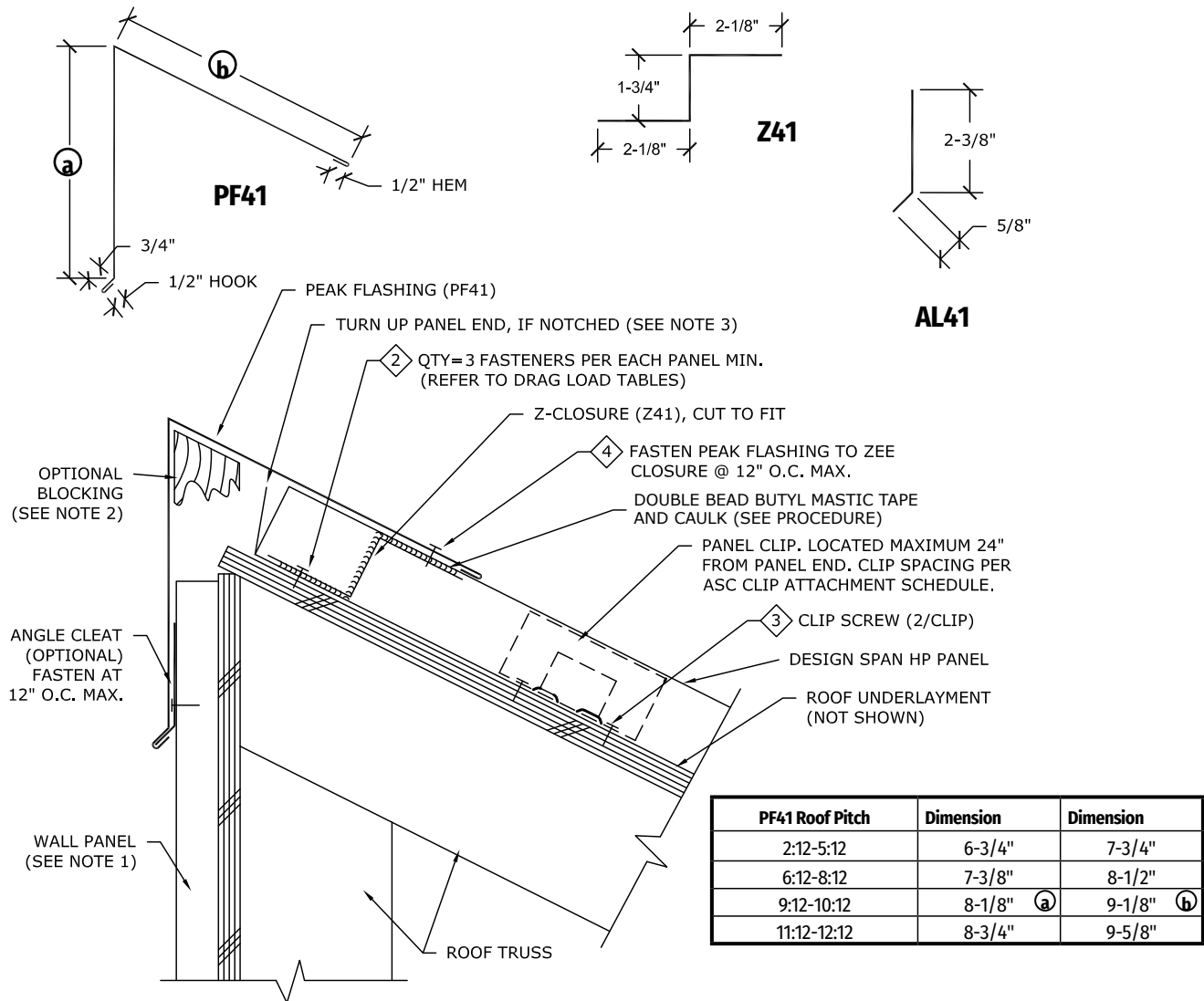

### Procedures

- Turn up uphill end of panels if notched (See note 3).
- Locate the panels down from the peak as required.
- Cut Z-closure to fit snug between panel ribs. Position Z-closure so that the peak flashing will conceal it.
- Caulk the bottom of the Z-closure. Check the panel positioning at the eave before fastening the Z-closure.
- Apply double bead butyl mastic tape to top and bottom of Z-closure. Fasten Z-closure to panel and caulk ends of Z-closure to pan ribs. Fasten the peak flashing over the Z-closure.
- Caulk, lap, and rivet sequential flashings. ASC recommends that the maximum accumulated length of flashings do not exceed 40 ft.
- Close the ends of the peak at gable ends by slitting

and folding material at each end, caulking joints, and fastening with rivets.

#### Notes:

1. Peak flashing dimensions noted on this installation detail are based on a nominal 1" thick wall facing. Different wall panel thicknesses may require some adjustments to peak flashing dimensions and/or positioning of roof assembly components.
2. Additional blocking may be required at peak to support peak flashing.
3. If panels are factory notched, 1-1/8" notches are provided on BOTH ends of panel. Ordered panel lengths must be adjusted accordingly to account for the combined 2-1/4" of notched length.

## Vented Peak Flashing

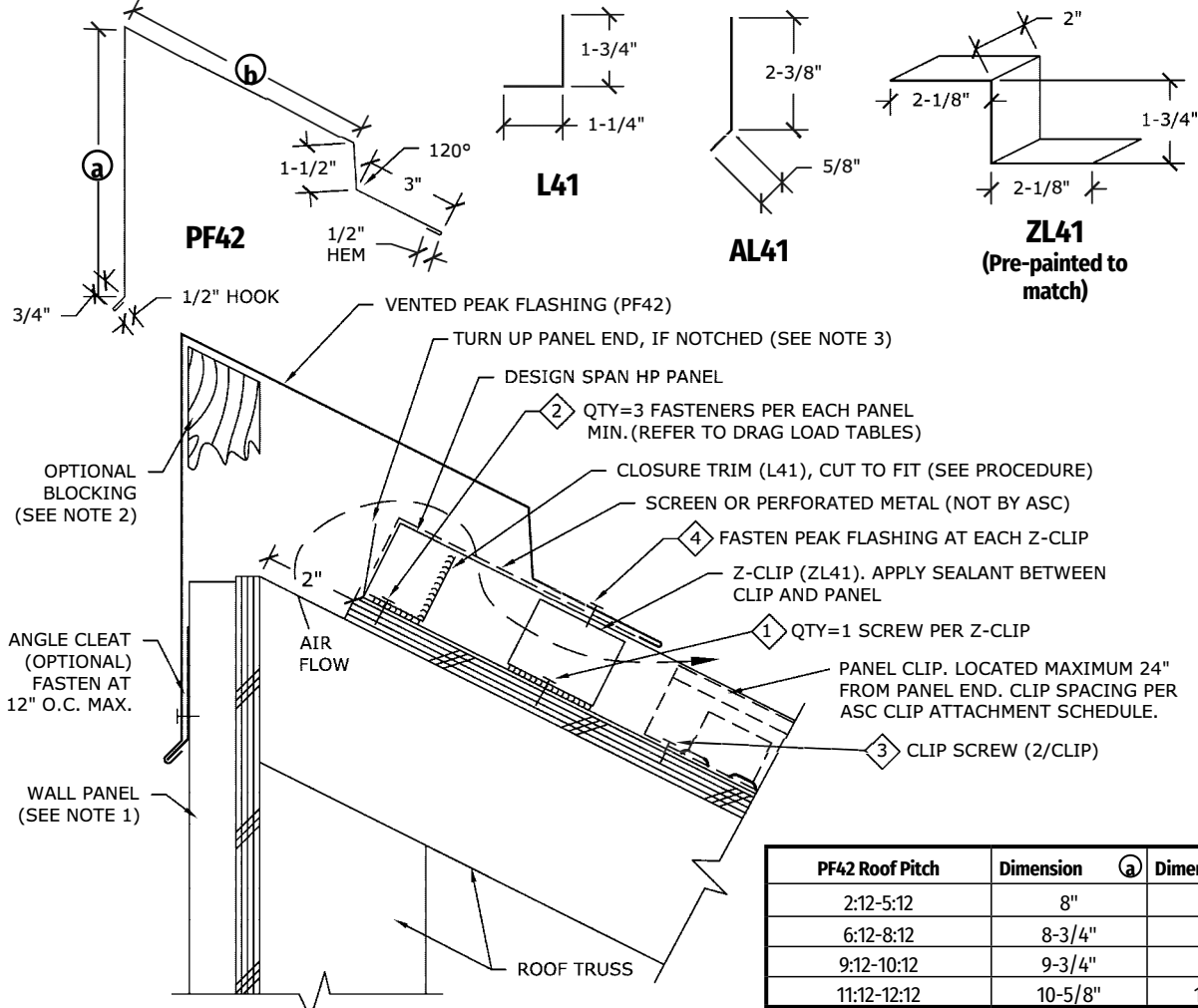

### Procedures

- Substrate should be held back 2" from peak for venting.
- Turn up end of panels if notched (See note 3).
- Position the panels at the top edge of the substrate.
- Cut L-closure to fit between snug between panel ribs. Apply double bead butyl mastic tape to the bottom of the L-closure. Position the L-closure as shown in drawing. Check the panel positioning at the eave before fastening the L-closure and panel to the substrate. Caulk the sides of L-closure against the vertical ribs of the panel, sealing off all openings.
- Locate the Z-clip so that the Vented Ridge can be fastened to it. Position clip so that it will be hidden underneath the installed peak flashing. Refer to vented ridge installation detail for additional Z-clip information.
- Caulk the bottom of the Z-clips and attach to panel with screw.

- Set the perforated vent metal on top of the roof panel and Z-clips. Fasten the peak flashing, perforated metal and Z-clips as shown.
- Caulk, lap, and rivet sequential flashings. ASC recommends that maximum accumulated length of flashings do not exceed 40 ft.
- Close the end of the peak flashings at gable ends by slitting and folding the material at each end, caulking joints, and fastening with rivets.

### Notes:

1. Peak flashing dimensions noted on this installation detail based on nominal 1" thick wall facing. Different wall panel thicknesses may require some adjustments to peak flashing dimensions and/or positioning of roof assembly components.
2. Additional blocking may be required at peak to support peak flashing.
3. If panels are factory notched, 1-1/8" notches are provided on BOTH ends of panel. Ordered panel lengths must be adjusted accordingly to account for the combined 2-1/4" of notched length.

## Sidewall Flashing

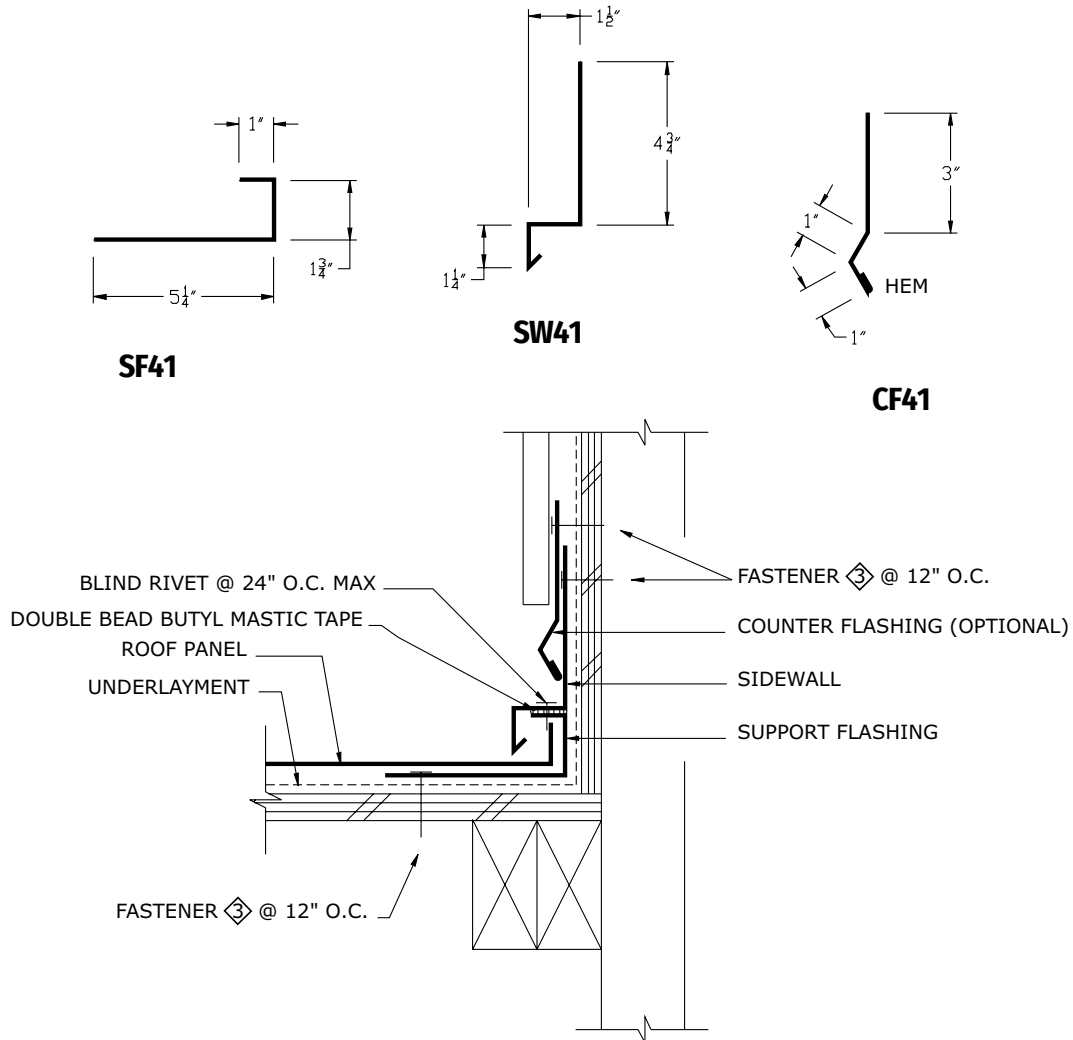

### Procedures

- The support flashing should be installed prior to the roofing panel.
- Cut the panel and turn up the edge as shown.
- Place butyl mastic tape between the sidewall flashing and support flashing as shown.
- Caulk, lap, and rivet sequential flashings. We recommend that maximum accumulated length of flashings do not exceed 40 ft.
- Attach the counter flashing if used.
- Cut, caulk, fold, and rivet the end of the sidewall flashing (similar to the gable preparation).

## Endwall Flashing

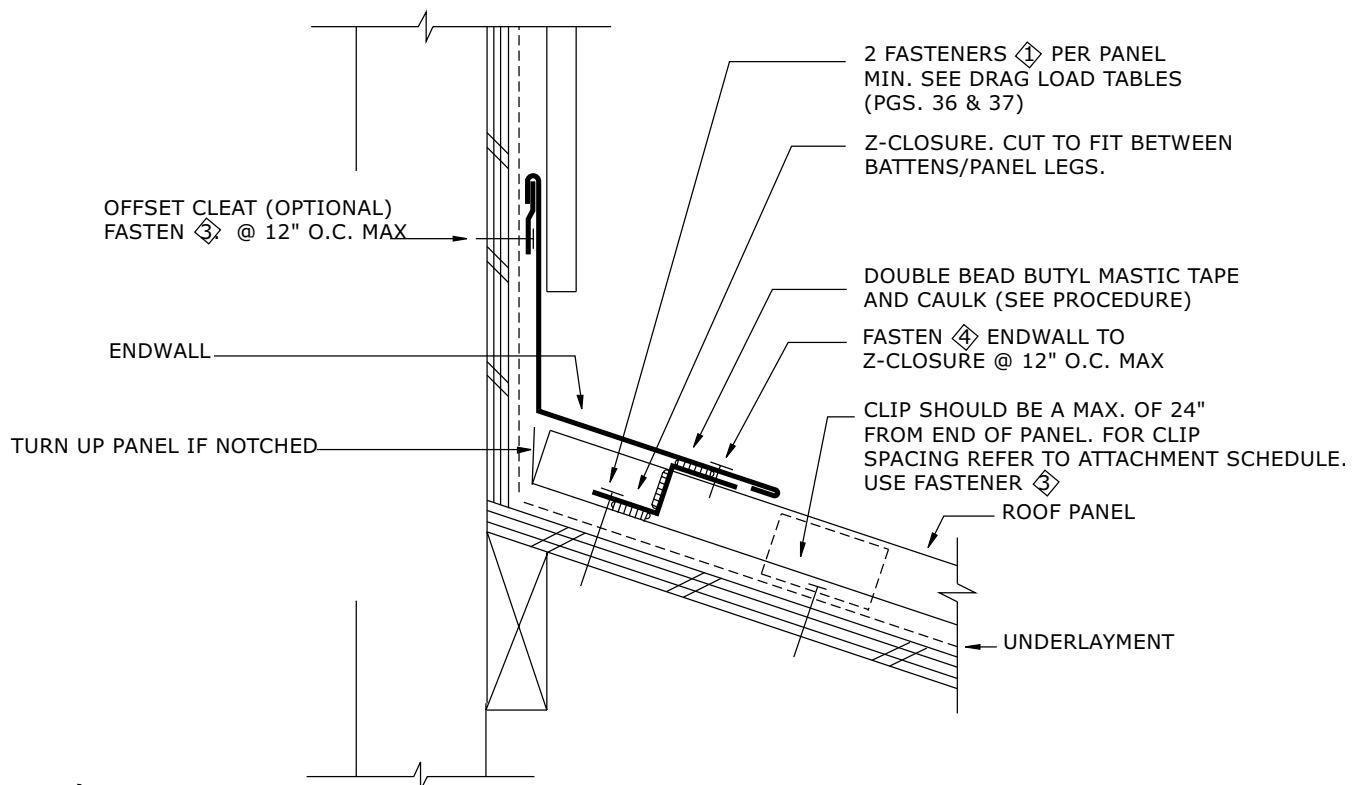
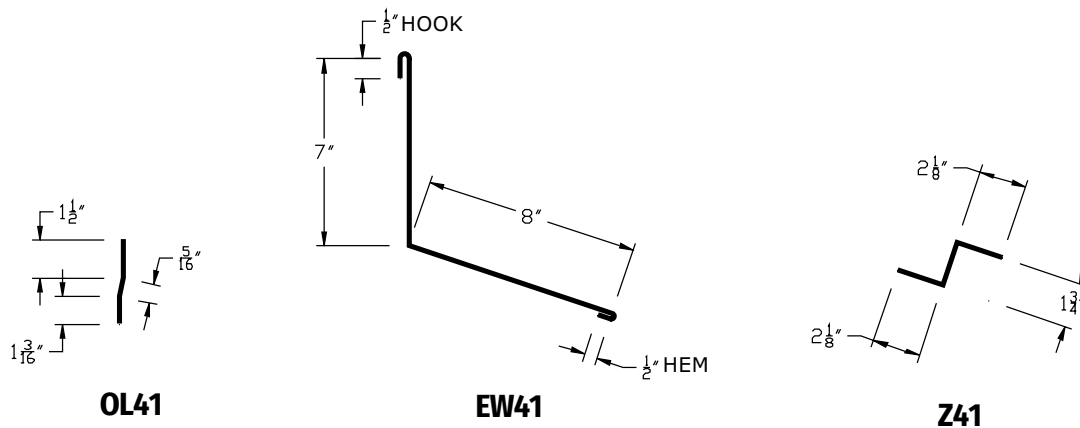

### Procedures

- Turn up end of panels if notched. If panels are factory notched, 1-1/8" notches are provided on BOTH ends of panel. Ordered panel lengths must be adjusted accordingly to account for the combined 2-1/4" of notched length.
- Locate the panels down from the endwall as required and position Z-closure so that the endwall flashing will conceal it.
- Apply double bead butyl mastic tape to top and bottom of Z-closure.
- Fasten the Z-closure to the substrate and caulk closure ends against panel ribs.
- Fasten endwall flashing to the Z-closure.
- Caulk, lap, and rivet sequential flashings. We recommend that maximum accumulated length of flashings do not exceed 40 ft.



## Drip Flashing

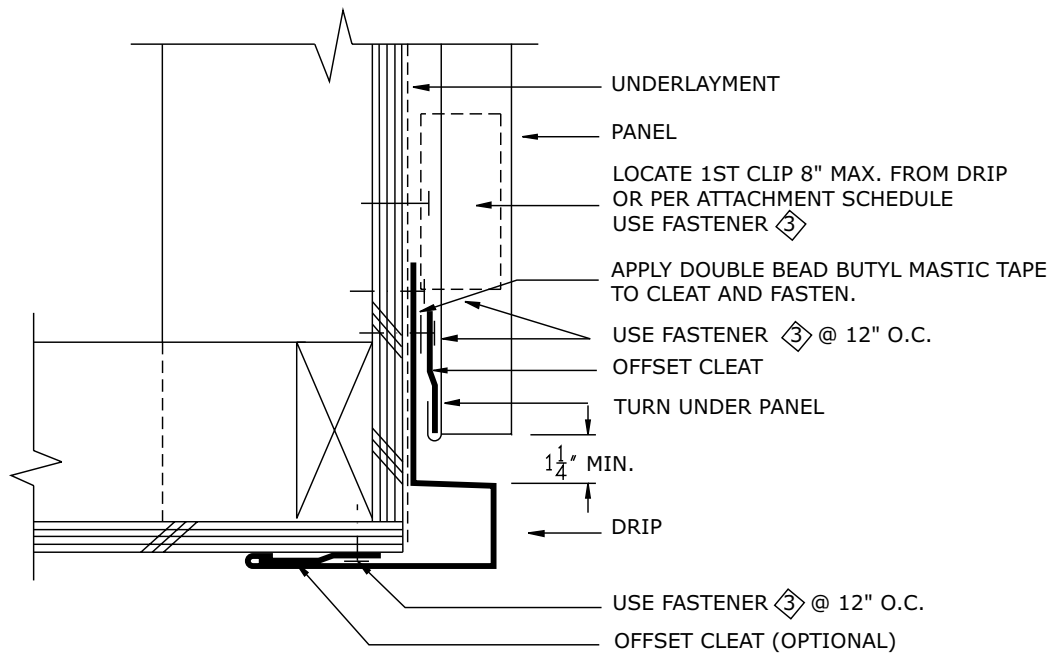
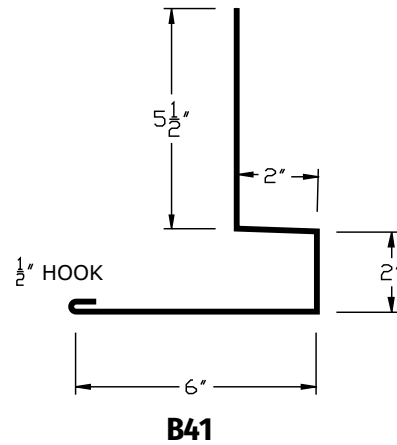
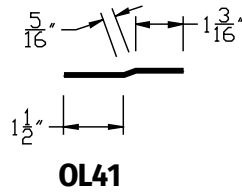

### Procedures

- Locate and fasten the offset cleat for the drip flashing. If the cleat is not used the horizontal leg of the drip flashing must be fastened through to the substrate with a #14 wood screw every 24" O.C. max.
- Locate the offset cleat so that the fascia panels can hook around it. Allow at least 1 1/4" clearance as shown.

## High Slope Low Slope Transition

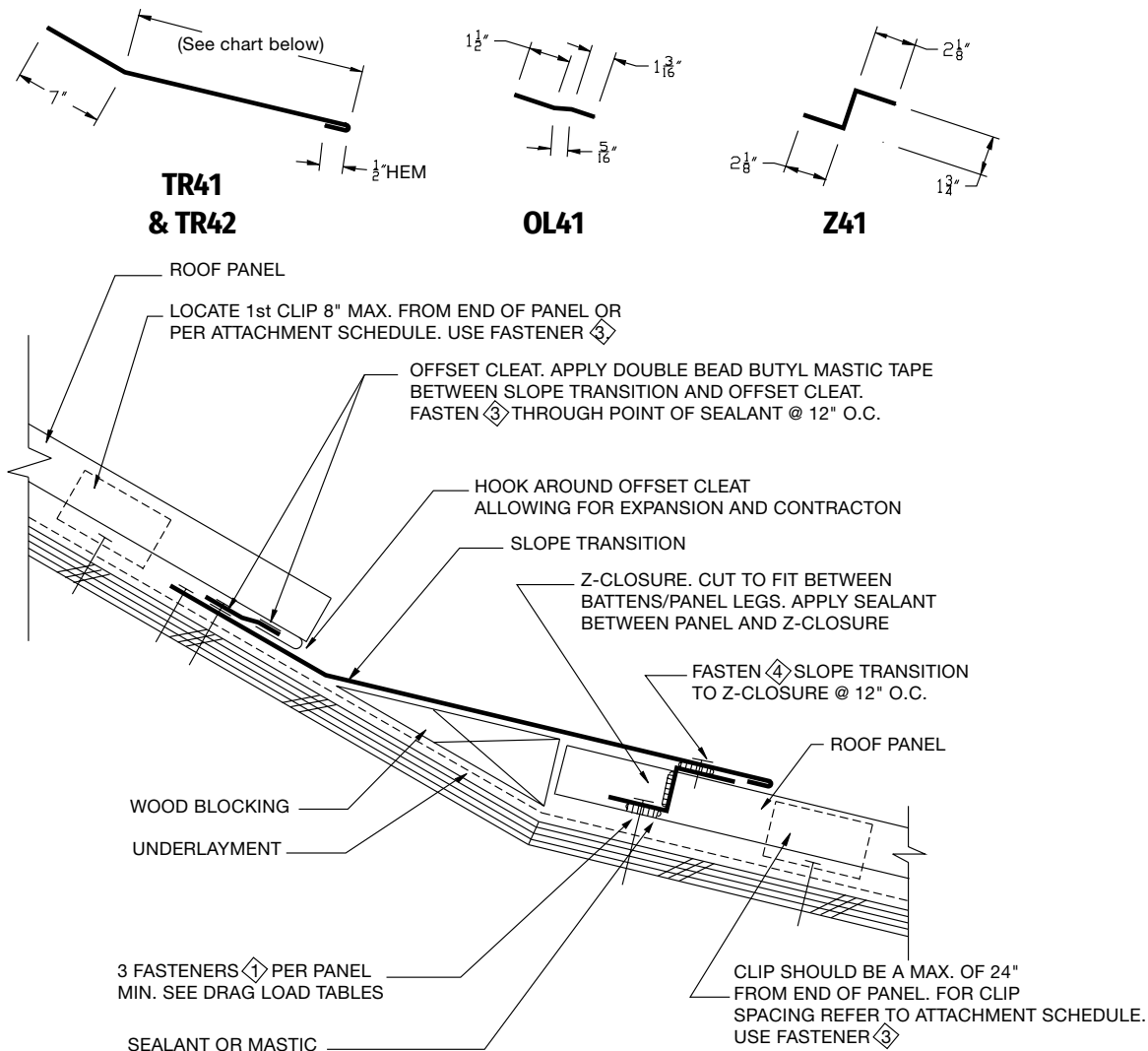

### Procedures

- Position the lower panels to allow proper location of Z Closure as shown.
- Turn up panel if notched. If panels are factory notched, 1-1/8" notches are provided on BOTH ends of panel. Ordered panel lengths must be adjusted accordingly to account for the combined 2-1/4" of notched length.
- Apply double bead butyl mastic tape to top and bottom of Z-closure.
- Fasten Z-closure and caulk ends against panel ribs.
- Install wood blocking as needed for support.
- Locate the transition flashing and attach to the substrate and Z-closure as shown.
- Attach the offset cleat. Apply double bead butyl mastic tape between the cleat and the transition flashing. Hook the uphill panel around the cleat allowing for expansion and contraction.
- Caulk, lap, and rivet sequential flashings. We recommend that maximum accumulated length of flashings do not exceed 40 ft.
- The roof pitch difference in the table is the upper roof pitch minus the lower roof pitch Example: 8:12 – 3:12 = 5:12. Use a 16.5" long flashing.

Part No.	Roof Pitch Difference	Varied Dimension
	1:12-2:12	Contact ASC
TR41	3:12-6:12	16.50"
TR42	7:12-12:12	8.50"

## Low Slope High Slope Transition

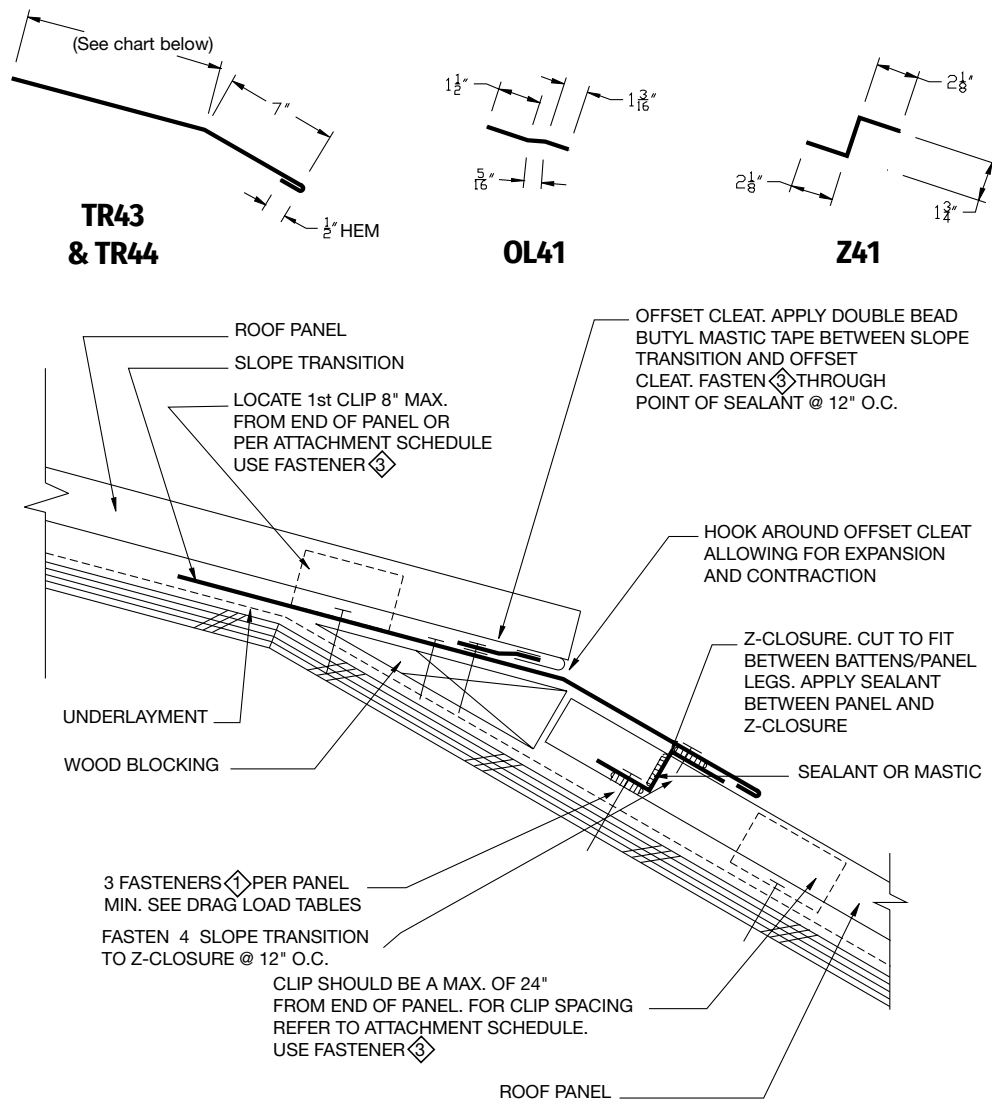

### Procedures

- Position the lower panels to allow proper location of Z Closure as shown.
- Turn up panel if notched. If panels are factory notched, 1-1/8" notches are provided on BOTH ends of panel. Ordered panel lengths must be adjusted accordingly to account for the combined 2-1/4" of notched length.
- Apply double bead butyl mastic tape to top and bottom of Z-closure.
- Fasten Z-closure and caulk ends against panel ribs.
- Install wood blocking as needed for support.
- Locate the transition flashing and attach to the substrate and Z Closure as shown.
- Attach the offset cleat. Apply double bead butyl mastic tape between the cleat and the transition flashing. Hook the uphill panel around the cleat allowing for expansion and contraction.
- Caulk, lap, and rivet sequential flashings. We recommend that maximum accumulated length of flashings do not exceed 40 ft.
- The roof pitch difference in the table is the lower roof pitch minus the upper roof pitch Example: 8:12 – 3:12 = 5:12. Use a 16.5" long flashing.

Part No.	Roof Pitch Difference	Varied Dimension
	1:12-2:12	Contact ASC
TR43	3:12-6:12	16.50"
TR44	7:12-12:12	8.50"

## Eave Transition

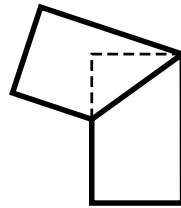

**DSPKNEE**

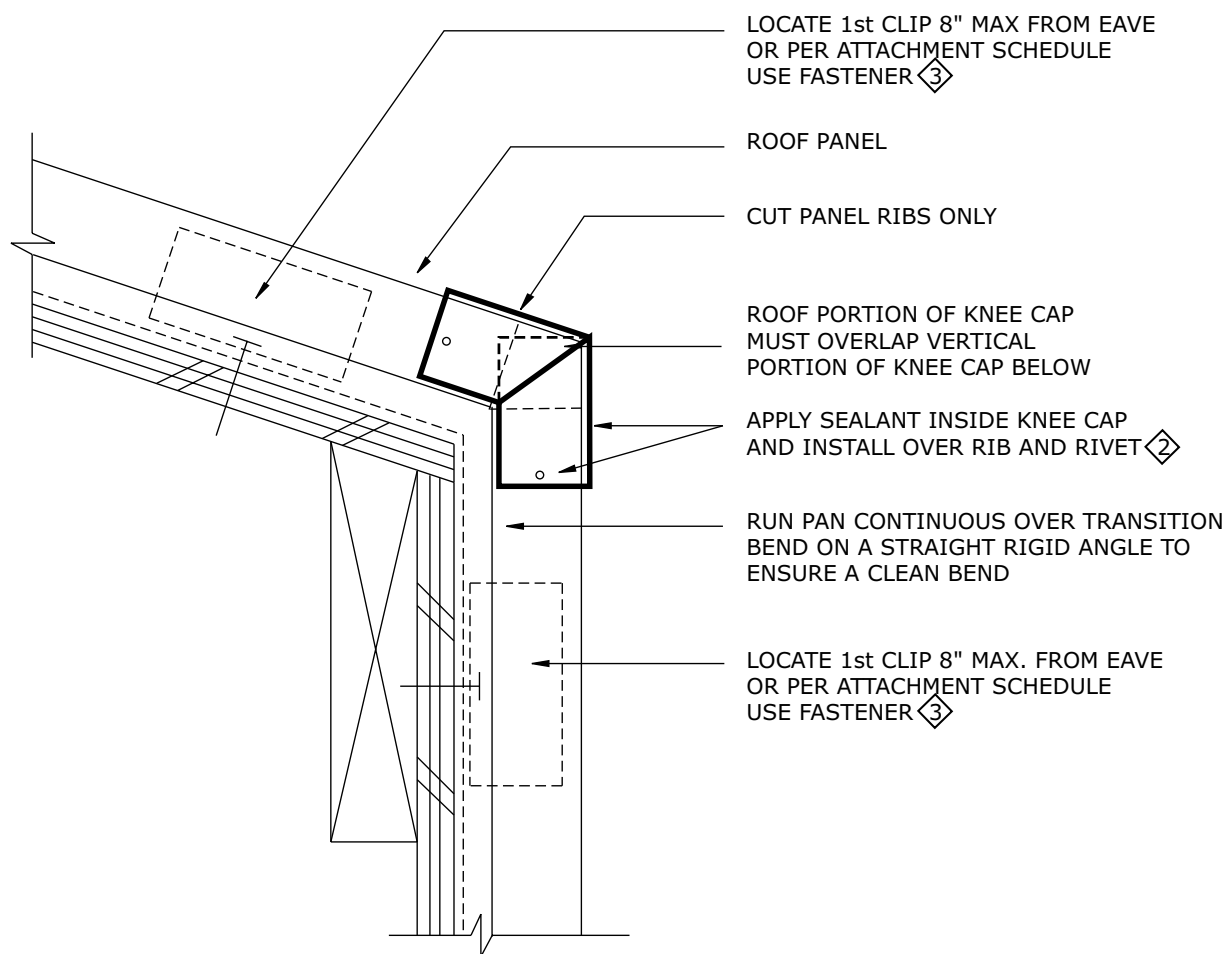

### Procedures

- Cut the panel ribs only where the panel is to bend. Bend panels over a straight, rigid angle to ensure a clean bend.
- Attach the roof panels.
- Caulk and cover the rib gap with the knee cap flashing and rivet.
- Due to expansion and contraction, this detail should not be used when panels greater than 40 ft. are used.

**Note:** This detail shall not be used in applications that are subject to snow and ice.

## Vent Flashing

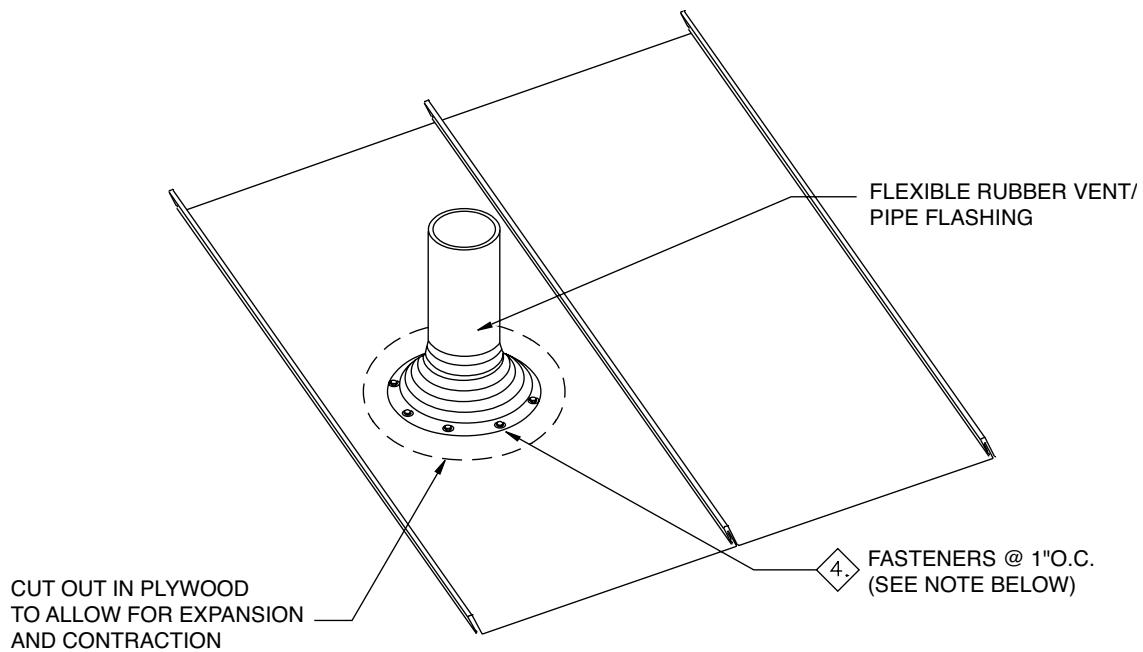

**Note:** When a penetration occurs through the panel sidelap, you must use the skylight/chimney curb details on pages 29 – 33.

**Note:** In many cases it may be easier to locate vent/pipe flashing in the flat area of the roof panel (as shown) rather than have the penetration occur at a panel rib. Determining panel layout prior to installation often simplifies penetration flashing installation.

### Procedures

- Trim the opening in the flexible rubber flashing to 20% smaller than the pipe diameter.
- Slide the flashing down over the pipe.
- Seal between the flashing and the roofing with gunnable caulk and set the flashing.
- Form the flashing to fit the profile of the roof.
- Fasten the flashing with #14 x 7/8" Lap Self-Driller screws at 1" o.c.

**Important note:** When a pipe penetration occurs further than 10 ft. from the top end of a roof panel, the roof substrate hole must be large enough so that the fasteners for the flexible rubber penetration flashing do not "pin" the panel to the substrate. For pipe penetrations within 10 ft. of the top end of the panel, the flexible rubber flashing may be screwed to the substrate with #14 wood screws.

## Skylight/Chimney Curb Details

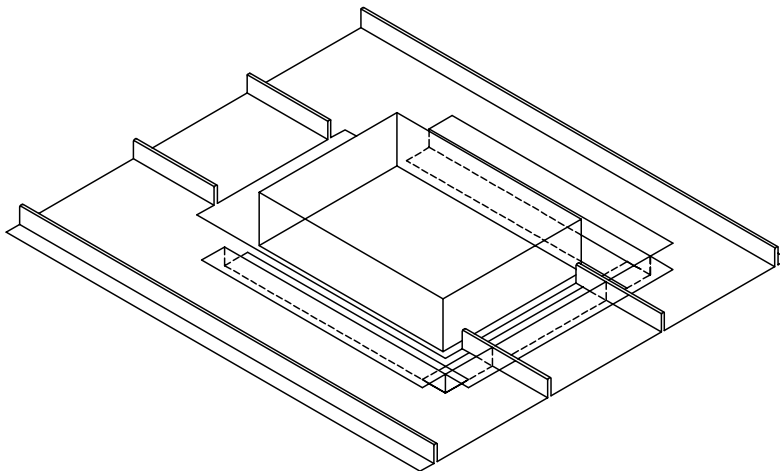

**Curb Detail with Zee Closures**

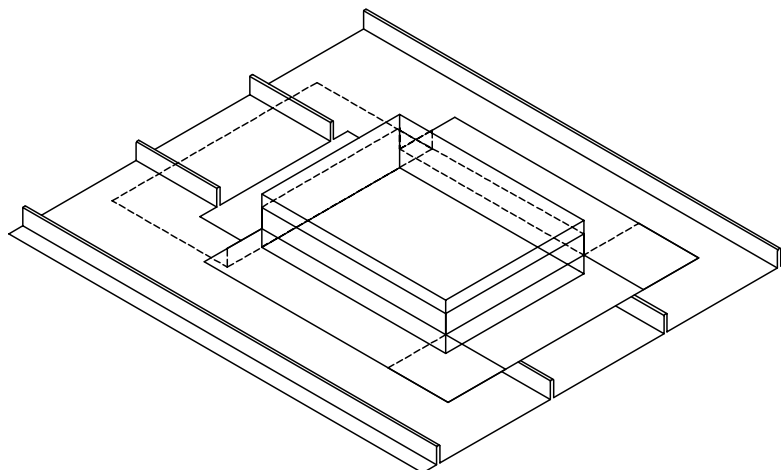

**Curb Detail with Flashing**

### Procedures

- Whenever possible, position the skylight curb so the ribs of the roof panels do not interfere with the flashings.
- Cut the roof panels as close to the left, right and downhill sides of the curb as possible. Cut the uphill side 6" up from the curb as indicated on page 31.
- The skylight flashing will be 10" wider than the width of the curb (5" on each side).
- Make sure all Z Closures have butyl mastic tape and sealant on the top, bottom, and sides.
- Apply liberal amounts of sealant where the Z Closures and flashings meet to insure weather tightness.

## Skylight/Chimney Flashing (Uphill)

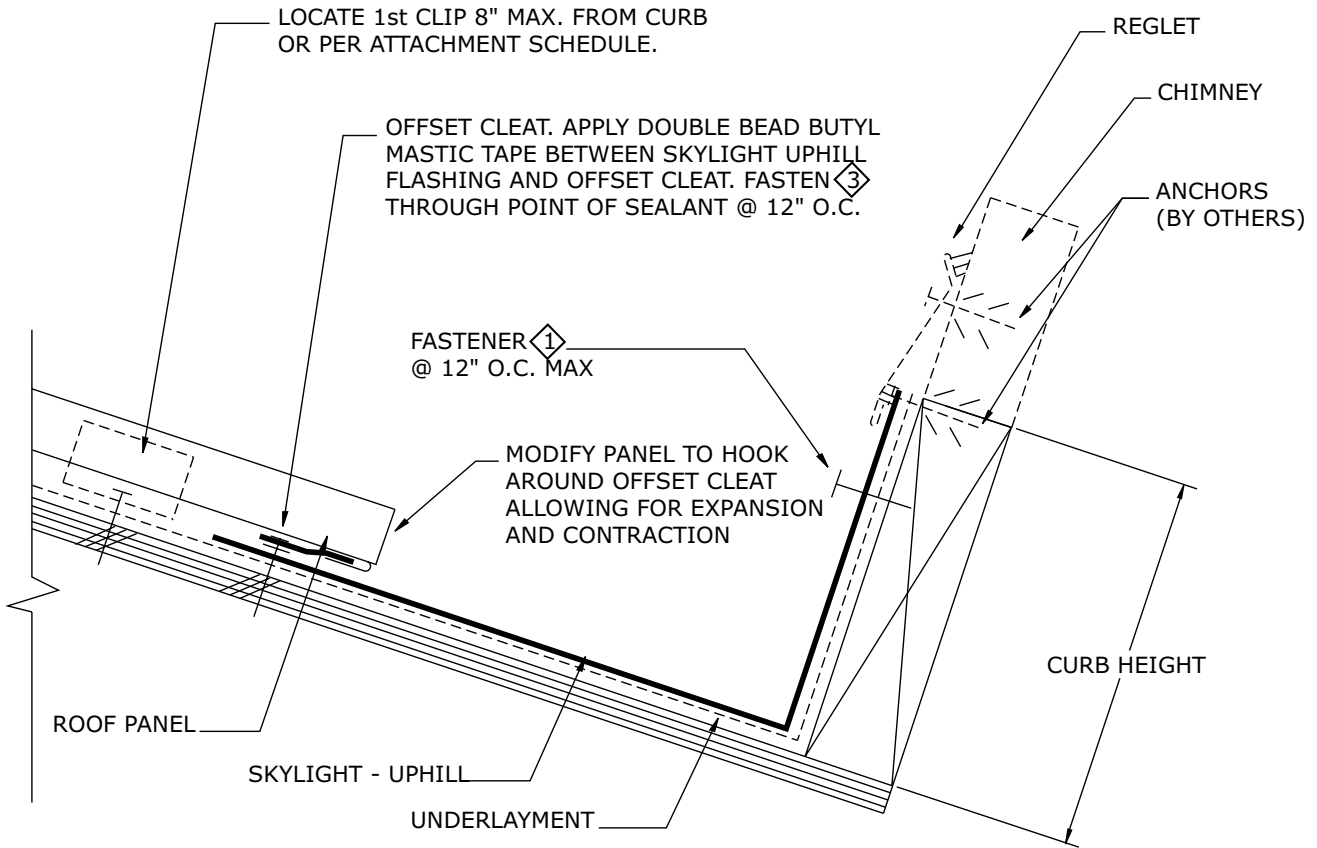
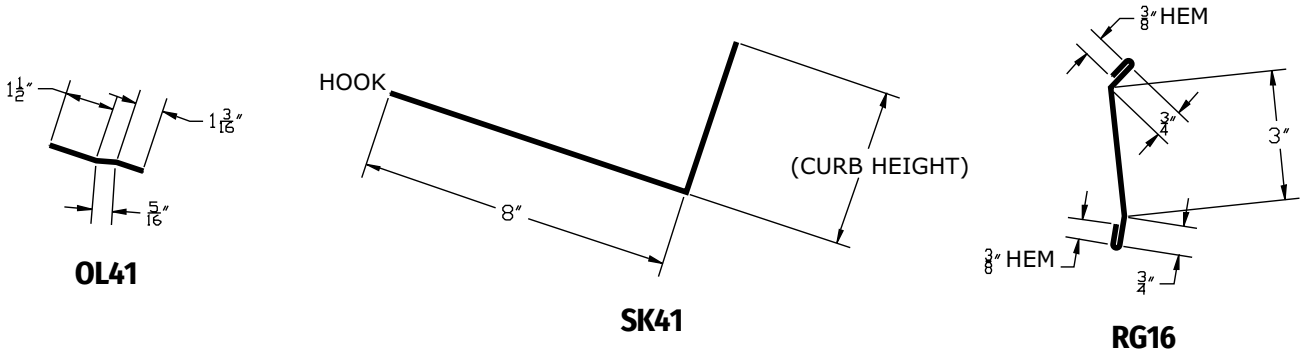

- Notes:**
- Do not fasten down the panels within 24" uphill from the skylight.
  - For chimney installation use a Reglet and Anchors.

# Skylight/Chimney Flashing (Downhill)

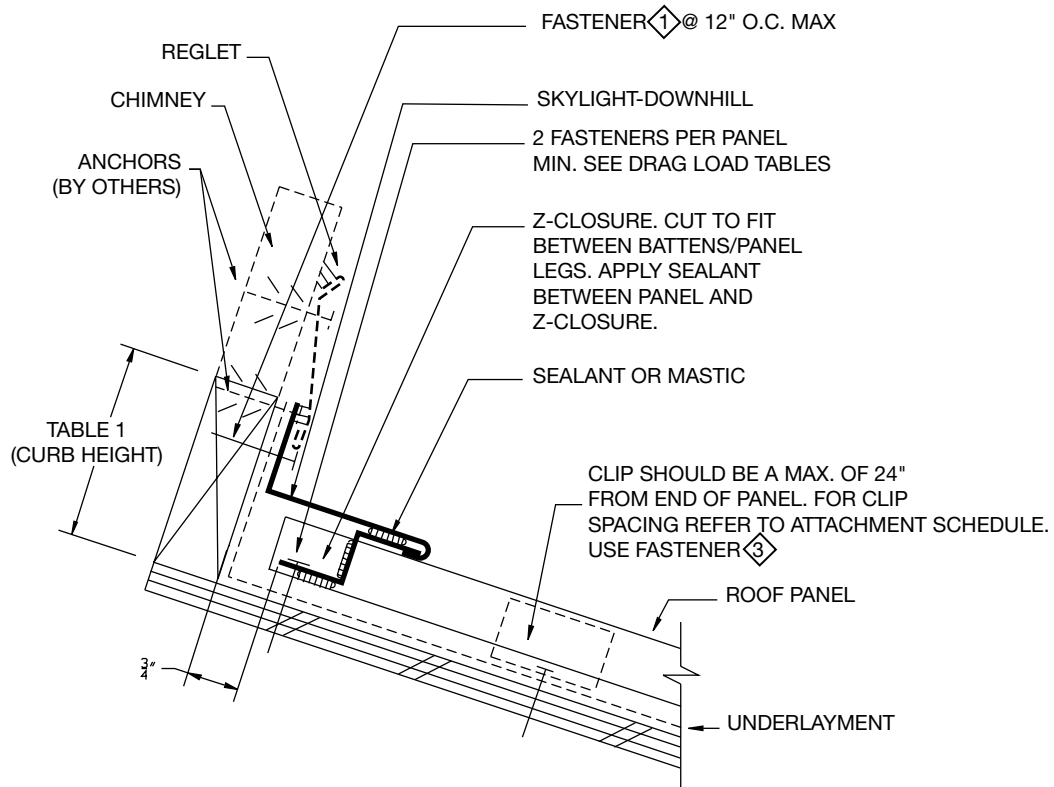
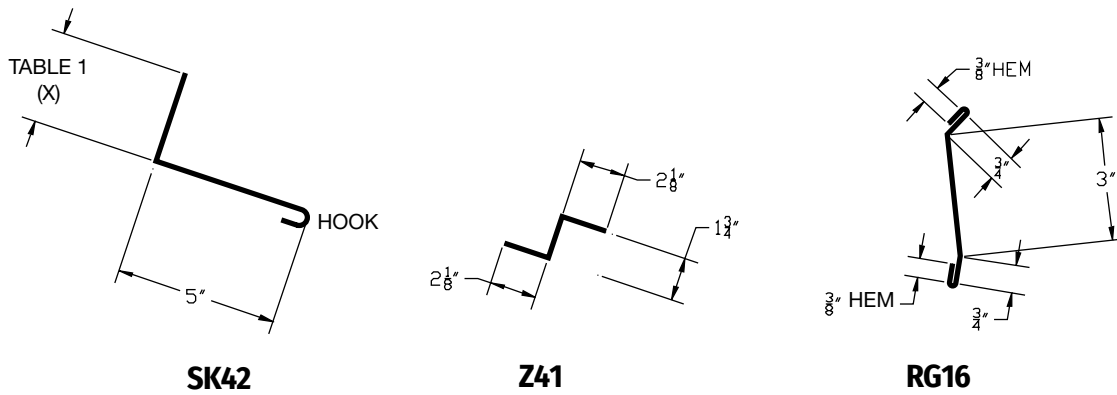
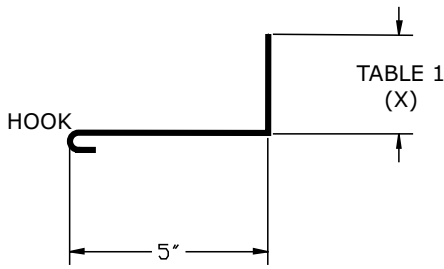

Table #1	
X	Curb Height
2 1/4"	4"
4 1/4"	6"
6 1/4"	8"
8 1/4"	10"

**Note:** For chimney installation use a Reglet and Anchors.



## Skylight/Chimney Flashing (Side)



**SK42**

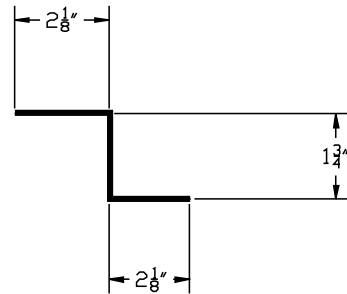

**Z41**

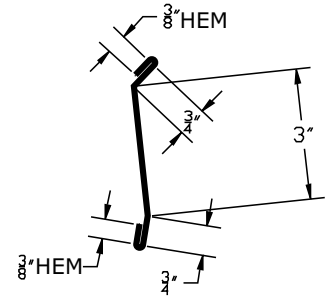

**RG16**

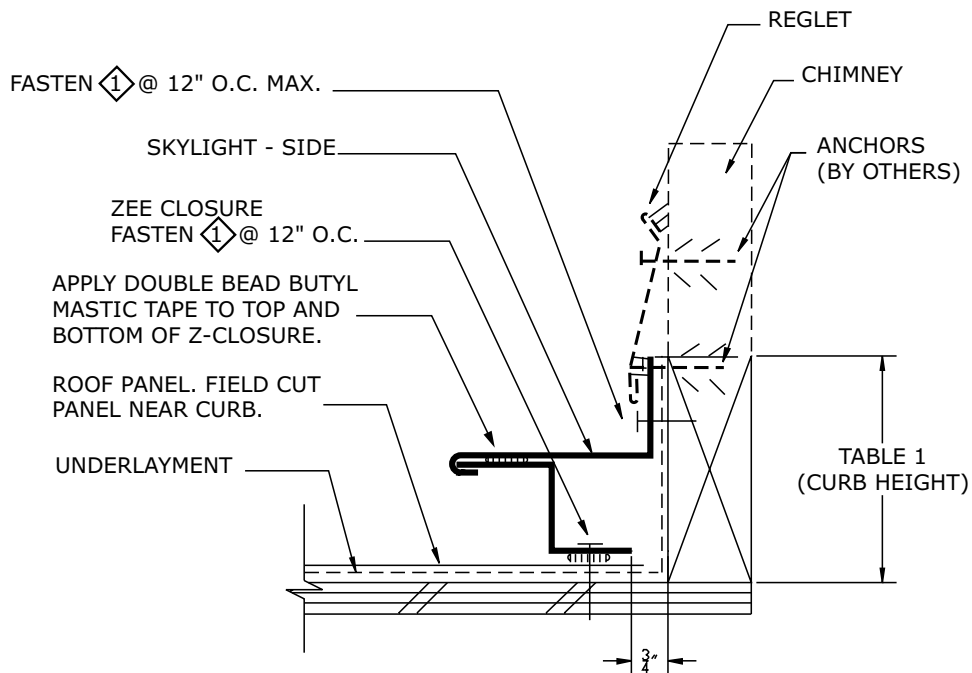
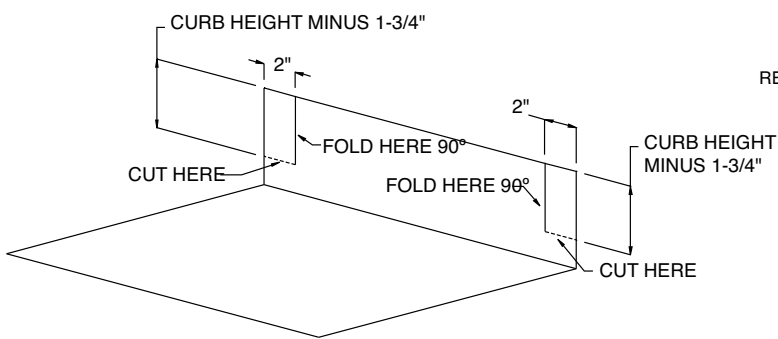
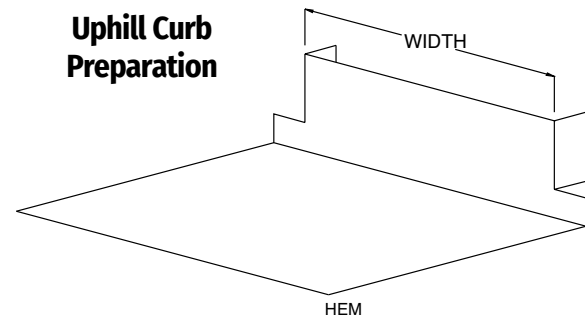

Table #1	
X	Curb Height
2 1/4"	4"
4 1/4"	6"
6 1/4"	8"
8 1/4"	10"

**Note:** For chimney installation use a Reglet and Anchors.

# Curb Preparation

## Uphill Curb Preparation



## Downhill Curb Preparation

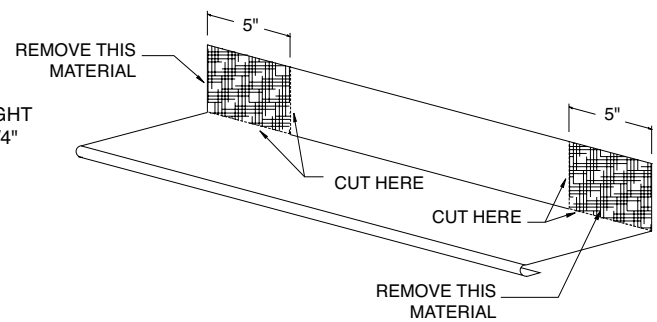
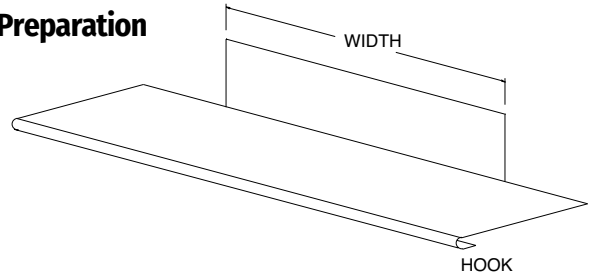

## Side Curb Preparation

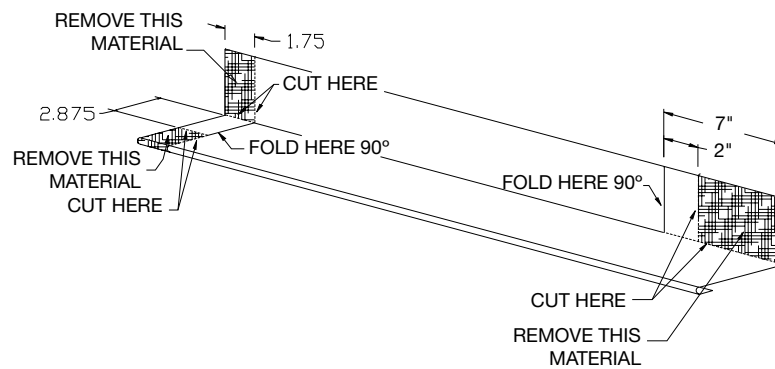
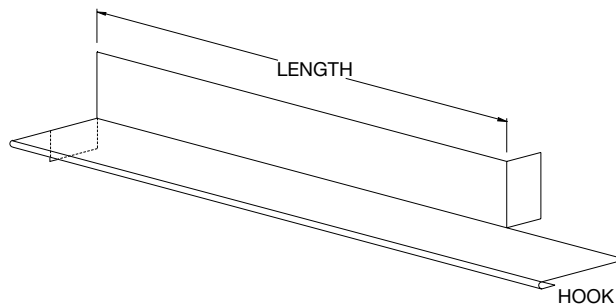

## Procedure for Joining Hems

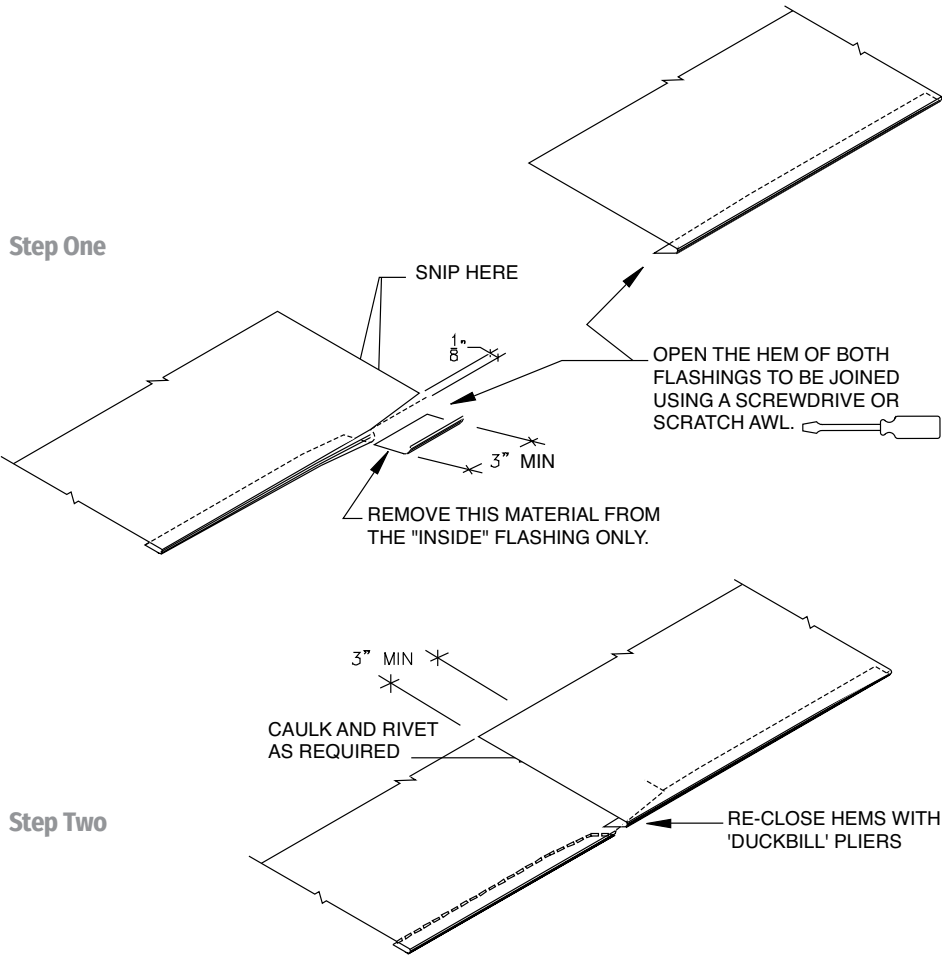

**Notes:**

- Flashings with accumulated length greater than 40 ft. need to allow for expansion and contraction.
- Expect about 1/8" thermal movement per 10 ft. section (panel or flashing).

## Valley Top End

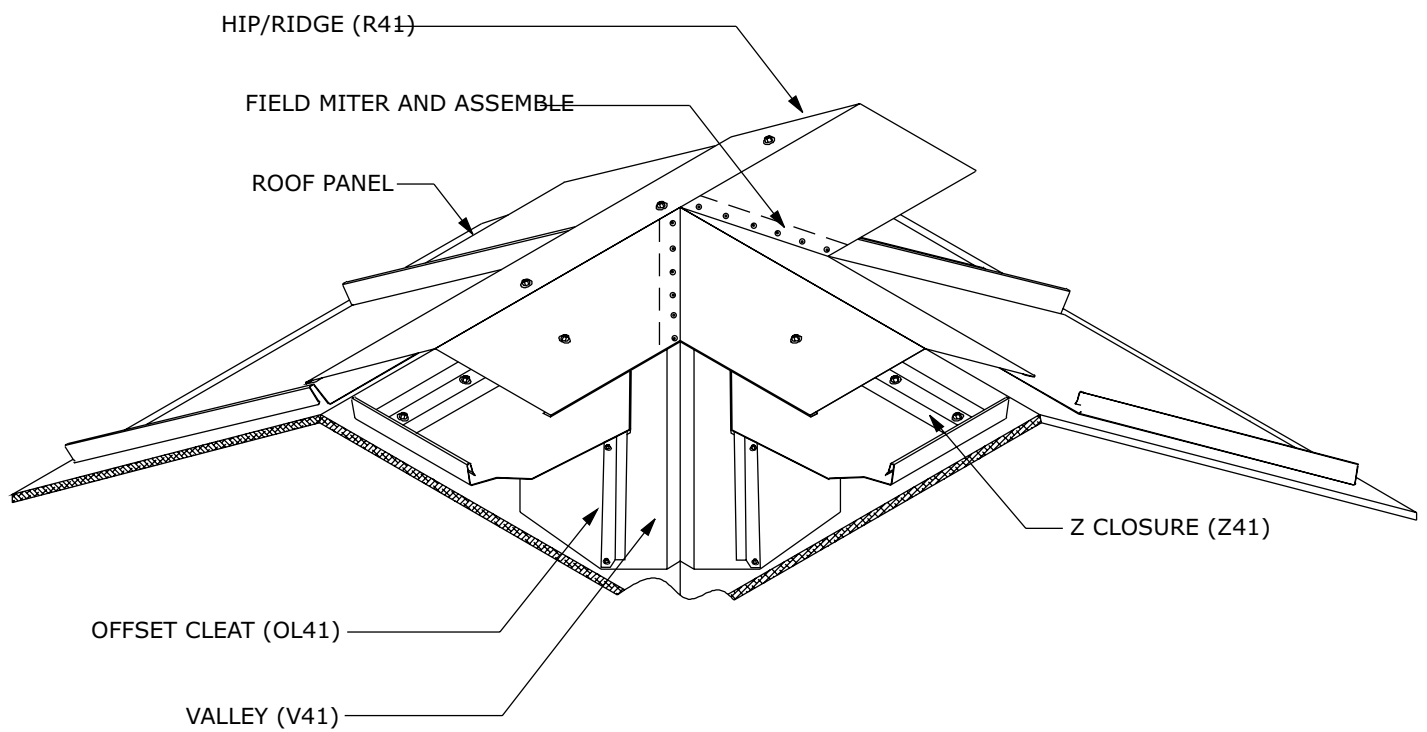

**Note:** Foam or metal closures and caulking are required between the intersecting ridge cap and the valley flashing to provide adequate weathertightness.

## Valley Dormer

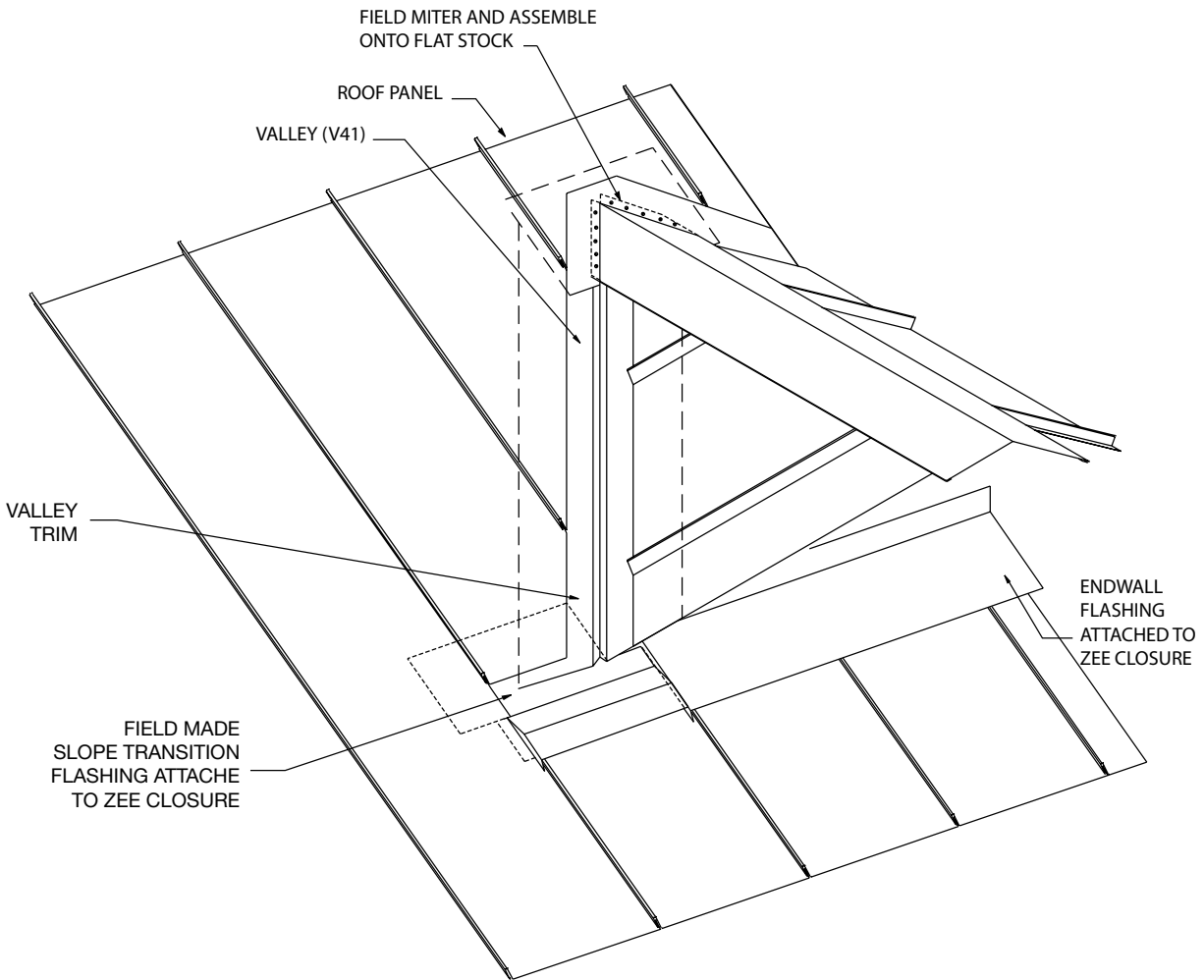

### Procedures

- Locate panel offset cleat (OL41) and install panels as shown in valley detail on page 19.
- Place a second layer of 36" roof felt in the valley center line with 18" of paper on each side.
- Caulk and lap the subsequent valley flashings a minimum of 8".
- Parallel to the valley, place two rows of butyl mastic tape spaced. Larger valleys, without the center V, may be required in snow country installations.
- Attach the panels to the roof and 'thru-fasten' along the bottom end using at the valley (4) #14 wood screws with washer evenly spaced and at 8" up from the valley so they align with the second row of tape sealant as shown on page 19.

### Notes:

- Valley dimensions must be the proper width to account for slope, snow, ice and rain conditions. An underlayment such as rubberized cold-applied membrane is recommended. The membrane is installed first, extending 3'-0" up from the center of the valley on each side, with felt overlapping the membrane.
- Foam or metal closures and caulking are required between the intersecting ridge cap and the valley flashing to provide adequate weathertightness.

# Appendix A

## Snow Drag Loads (lbs/ft of panel)

### 16" Design Span *hp*

Slope	Ground Snow Load, $P_g$ (psf)								
	25	30	35	40	45	50	55	60	65
2:12	6.7	8.0	9.3	10.6	12.0	13.3	14.6	16.0	17.2
3:12	9.8	11.7	13.7	15.6	17.7	19.6	21.5	23.5	25.4
4:12	12.7	15.2	17.9	20.4	23.0	25.5	28.1	30.6	33.2
5:12	15.5	18.6	21.7	24.8	28.0	31.0	34.1	37.3	40.3
6:12	18.0	21.7	25.3	28.9	32.4	36.1	39.7	43.3	46.9
7:12	20.3	24.4	28.4	32.5	36.5	40.7	44.8	48.8	52.9
8:12	22.4	26.9	31.3	35.8	40.3	44.8	49.2	53.7	58.2
9:12	24.2	29.0	33.9	38.7	43.6	48.4	53.2	58.1	62.9
10:12	25.8	31.0	36.2	41.3	46.5	51.7	56.7	62.0	67.2
11:12	27.2	32.7	38.1	43.6	49.0	54.5	60.0	65.5	70.9
12:12	28.6	34.2	39.9	45.6	51.3	57.0	62.8	68.5	74.2

### Snow Loads Exceeding 65 psf

#### Example:

16" Design Span *hp*

4:12 slope

120psf. snow load

40ft maximum sheet length

1. From table above, find the tabulated value at 4:12 slope and at 60 psf. snow load. (4:12, 60 psf. snow load = 30.6)
2. Multiply the tabulated value by 2 to obtain tabulated value at 120 psf. snow load. (30.6 x 2 = 61.2)
3. Multiply the tabulated value by the length to obtain drag load. (61.2 x 40 = 2,448 lbs.)

Note: There is not a limit for snow load. If the job required a 180 psf. snow load, the tabulated value would be (30.6 x 3 = 91.8) and so on.

Contact your ASC Building Products representative if you have any questions about the use of the Drag Load Tables.

### 17" Design Span *hp*

Slope	Ground Snow Load, $P_g$ (psf)								
	25	30	35	40	45	50	55	60	65
2:12	7.0	8.5	9.9	11.3	12.7	14.0	15.5	16.9	18.3
3:12	10.4	12.5	14.5	16.6	18.8	20.8	22.9	24.9	27.0
4:12	13.6	16.2	19.0	21.7	24.4	27.1	29.8	32.5	35.2
5:12	16.5	19.7	23.1	26.4	29.6	32.9	36.3	39.6	42.8
6:12	19.1	23.0	26.9	30.6	34.5	38.4	42.1	46.0	49.9
7:12	21.5	25.9	30.3	34.6	38.8	43.2	47.6	51.8	56.1
8:12	23.7	28.6	33.3	38.0	42.8	47.6	52.3	57.0	61.8
9:12	25.8	30.9	36.1	41.1	46.3	51.4	56.6	61.7	66.9
10:12	27.5	32.9	38.4	43.9	49.4	54.8	60.4	65.8	71.4
11:12	28.9	34.7	40.5	46.3	52.2	58.0	63.8	69.5	75.3
12:12	30.3	36.4	42.5	48.5	54.6	60.6	66.7	72.7	78.8

### 18" Design Span *hp*

Slope	Ground Snow Load, $P_g$ (psf)								
	25	30	35	40	45	50	55	60	65
7.5	9.0	10.4	12.0	13.4	14.9	16.5	17.9	19.4	17.2
11.0	13.2	15.4	17.7	19.8	22.0	24.2	26.4	28.6	25.4
14.4	17.2	20.1	23.0	25.8	28.7	31.6	34.5	37.3	33.2
17.4	20.9	24.4	28.0	31.5	34.8	38.4	41.9	45.4	40.3
20.3	24.3	28.4	32.4	36.5	40.5	44.6	48.6	52.8	46.9
22.9	27.5	32.1	36.5	41.1	45.7	50.3	54.8	59.4	52.9
25.2	30.3	35.2	40.3	45.3	50.3	55.4	60.4	65.5	58.2
27.2	32.7	38.1	43.6	49.0	54.5	59.9	65.3	70.8	62.9
29.0	34.8	40.7	46.5	52.3	58.1	63.9	69.7	75.5	67.2
30.6	36.8	43.0	49.0	55.2	61.3	67.4	73.6	79.7	70.9
32.1	38.5	44.9	51.3	57.7	64.1	70.5	77.0	83.4	74.2

#### Notes:

- 1) To determine drag load forces per panel, multiply the tabulated value by the panel length. Then refer to Appendix B for fastener schedule.
- 2) Values assume Ground Snow Load ( $P_g$ ) is provided. Drag Loads may be reduced if actual Roof Snow Loads ( $P_s$ ), per ASCE-7, are provided by customer.
- 3) For roof slopes and snow loads greater than listed above, please contact your ASC Building Products representative.

## Appendix B

### Drag Load Resistance

Fastener Type	Substrate	Capacity (lbs)	Number of Fasteners per Panel								
			2	3	4	5	6	7	8	9	10
#12-14 x 1" SD HWH	16ga Steel min.	234	468	702	936	1170	1404	1638	1872	2106	2340
1/4-14 x 7/8" Lap SD HWH	22ga Steel min.	184	368	552	736	920	1104	1288	1472	1656	1840
#14 x 1" Type A Mill. Point HWH	1/2" Plywood/ OSB min.	128	256	384	512	640	768	896	1024	1152	1280
#14 x 1" Type A Mill. Point HWH	2x Douglas Fir	57	114	171	228	285	342	399	456	513	570
#10-16 x 1" SD Pancake Head	16ga Steel min.	206	412	618	824	1030	1236	1442	1648	1854	2060
#10-16 x 1" SD Pancake Head	22ga Steel min.	154	308	462	616	770	924	1078	1232	1386	1540
#10-12 x 1" Type A Pancake Head	1/2" Plywood/ OSB min.	108	216	324	432	540	648	756	864	972	1080
#10-12 x 1" Type A Pancake Head	2x Douglas Fir	54	108	162	216	270	324	378	432	486	540

**Example::**

16" Design Span *hp* attached to 1/2" plywood/OSB.

4:12 slope

30psf snow load

40ft maximum panel length

#10-12 pancake head fasteners used

1. From Appendix A, find the drag load per linear foot of panels: 4:12 & 30psf snow load = 15.2lbs/ft
2. Multiply the load by the panel length = 15.2lbs/ft X 40 ft = 608lbs drag load per panel.
3. Find the drag load in Appendix B.  
 The nearest value is 648lbs for Qty = 6, #10-12 x 1" type A pancake head fasteners.

**Notes:**

- 1) Contact your ASC Building Products representative if there are any questions regarding the use of these appendices.
- 2) Fasteners must be located a minimum of 1" from each other and from the end of the panel.

Manufacturing Facilities:

**West Sacramento, California**  
2110 Enterprise Boulevard  
West Sacramento, CA 95691

**Salem, Oregon**  
4063 Salem Industrial Drive NE  
Salem, OR 97303  
Customer Service Center  
800-272-7023 • 503-390-7174

**Spokane, Washington**  
4111 East Ferry Avenue  
Spokane, WA 99202  
Customer Service Center  
800-776-8771 • 509-536-4097

Corporate Headquarters:

**ASC Profiles**  
2110 Enterprise Boulevard  
West Sacramento, CA 95691

Visit us at our website:  
**[www.ascbp.com](http://www.ascbp.com)**

